

GARMIN®

inReach® Mini 3/3 Plus

Satellite Communicator



Owner's
Manual

Table of Contents

Introduction.....	4	Apps.....	14
Getting Started.....	4	Garmin Share.....	14
Device Overview.....	4	Sharing Data with Garmin Share.....	14
Buttons.....	5	Receiving Data with Garmin Share..	15
Controls.....	5	Saved Data.....	15
Action Menu.....	6	Using the Saved App.....	15
Pairing Your Phone and Activating the		Viewing Saved Data.....	15
Device.....	6	Deleting Saved Data.....	15
Garmin Messenger™ App.....	6	Using Voice Commands.....	16
Garmin Explore™.....	7	Voice Commands.....	16
Iridium® Satellite Network.....	7	Recording a Voice Note.....	16
Bluetooth® Connected Features.....	7	Weather.....	17
Testing the Device.....	7	Viewing a Weather Forecast.....	17
inReach® Features.....	8	Adding a Waypoint as a Weather	
inReach® Tracking.....	8	Location.....	17
Starting Tracking.....	8	Setting the Weather Location.....	17
Navigating to the Start of Your Current		Requesting an inReach® Weather	
Track.....	8	Forecast.....	17
Stopping Tracking.....	8	Updating an inReach® Weather	
Sharing Your Tracking Page.....	8	Forecast.....	18
Messages.....	9	Deleting a Weather Location.....	18
Sending a Check-In Message.....	9	Navigation.....	19
Sending a Text Message.....	9	Acquiring GPS Satellite Signals.....	19
Sending a Post Message.....	9	Panning and Zooming the Map.....	19
Replying to a Message.....	9	Navigating Using TracBack®.....	19
Reacting to a Message.....	10	Navigating to Known Coordinates.....	19
Downloading Photo and Voice		Viewing Your Current Coordinates.....	19
Messages.....	10	Navigating with Sight 'N Go.....	20
Checking for Messages.....	10	Stopping Navigation.....	20
Viewing Message Details.....	10	Compass.....	20
Navigating to a Message Location..	10	Navigating with the Compass.....	20
Deleting Messages.....	11	Calibrating the Compass.....	20
Contacts.....	11	Setting the Compass Heading.....	20
Adding a Contact.....	11	Compass Settings.....	20
Editing a Contact.....	11	Map.....	20
Deleting a Contact.....	11	Changing the Map Orientation.....	20
SOS.....	11	Waypoints.....	21
Initiating an SOS Rescue.....	11	Saving Your Current Location as a	
Sending a Custom SOS Message....	12	Waypoint.....	21
Canceling an SOS Request.....	12	Saving a Message Location as a	
Syncing inReach® Data.....	12	Waypoint.....	21
Viewing Plan Details and Usage.....	13	Saving a Location on the Map as a	
		Waypoint.....	21
		Navigating to a Waypoint.....	21
		Editing a Waypoint.....	21
		Deleting a Waypoint.....	22

Courses.....	22
Navigating a Saved Course.....	22
Reversing a Course.....	22
Activities.....	22
Starting an Activity.....	22
Customizing the Current Activity....	22
Viewing the Current Activity.....	23
Navigating a Saved Activity.....	23
Stopping the Current Activity.....	23

Saving Energy While Charging the Device.....	31
--	----

Customizing the Device..... 24

Sounds Settings.....	24
Phone Settings.....	24
inReach Remote Settings.....	24
Tracking Settings.....	24
Map Settings.....	24
System Settings.....	24
Time Settings.....	25
Units Settings.....	25
Satellite Settings.....	25
Setting Your Device Passcode.....	26

Device Information..... 27

Product Updates.....	27
Setting Up Garmin Express™	27
Getting More Information.....	27
Specifications.....	27
Battery Information.....	27
Viewing E-Label Regulatory and Compliance Information.....	28
Attaching the Spine Mount Adapter....	28
Attaching the Carabiner Tether.....	28
Attaching a Lanyard.....	29
Locking and Unlocking the Device.....	29
Locking and Unlocking the Touchscreen.....	29
Capturing a Screenshot.....	29
Device Care.....	30
Cleaning the Device.....	30
Cleaning the USB Port.....	30
Cleaning the Touchscreen.....	30
Troubleshooting.....	30
Maximizing Battery Life.....	30
My device is in the wrong language.....	30
Resetting All Default Settings.....	30
Charging the inReach® Device.....	31

Introduction

⚠ WARNING

See the *Important Safety and Product Information* guide in the product box for product warnings and other important information.

Getting Started

When using your inReach® satellite communicator the first time, you should complete these tasks to set it up and get to know the basic features.

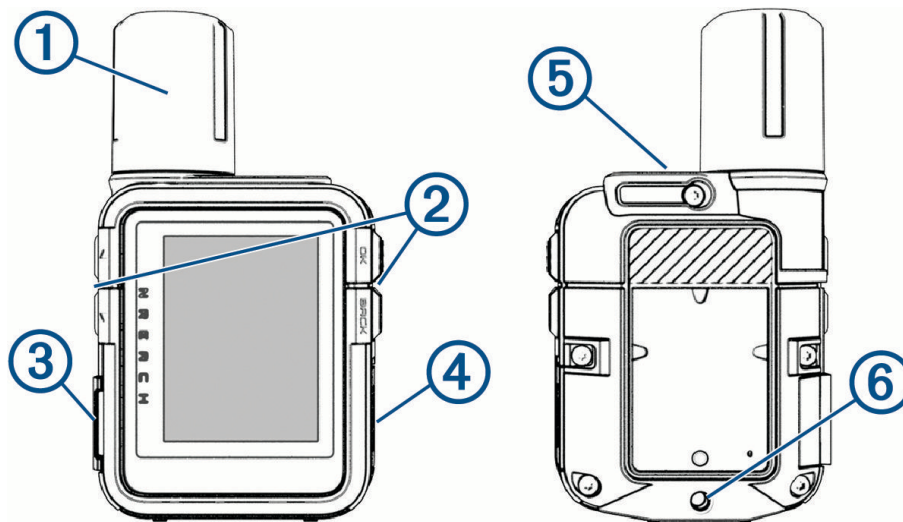

- 1 Press  to turn on the device.
- 2 Follow the on-screen instructions to select your language and begin activating your device.
- 3 Download the Garmin Messenger™ app to your phone, and follow the on-screen instructions to pair and activate your device ([Pairing Your Phone and Activating the Device, page 6](#)).
You can use the Garmin Messenger app to compose and send messages using your phone.
- 4 Download the Garmin Explore™ app to your phone, and log in with the account information you used to activate a service plan.
You can use the Garmin Explore app for planning adventures, navigating, and backing up data from your device.
- 5 If necessary, create a passcode to secure your device ([Setting Your Device Passcode, page 26](#)).
- 6 Check for updates ([Product Updates, page 27](#)).
For the best experience, you should keep the software on your device up to date. Software updates provide changes and improvements to privacy, security, and features.
- 7 Sync your satellite communicator with the Garmin Messenger app ([Syncing inReach® Data, page 12](#)).
- 8 Test your satellite communicator before you begin your trip ([Testing the Device, page 7](#)).

Device Overview















①	Internal Iridium® antenna
②	Buttons
③	SOS button (under protective cap)
④	USB port (under weather cap)
⑤	 Power button
⑥	Spine mount adapter screw insert

Buttons

	Press to scroll through menus, pages, and settings. From the home page, press to view the apps.
	Press to scroll through menus, pages, and settings. From the home page, press to view the apps.
BACK	Press to cancel or return to the previous page. Hold to open the action menu.
OK	Press to choose an option or to acknowledge a message. Press to open the options menu for the page that is currently open (if available). Hold to open voice commands on the inReach® Mini 3 Plus satellite communicator.
	Press to turn the device on. Press to lock the touchscreen. Hold to open the controls.









Status Icons

	Transmitting data
	Tracking enabled
	Navigating
	Unread messages
	Sounds muted
	Buttons locked
	Charging battery
	Charging complete
	Exceeding maximum or below minimum charging temperature
	Approaching minimum operating temperature
	Approaching maximum operating temperature
	Exceeding maximum or below minimum operating temperature

Controls

Controls provide quick access to frequently used functions.

Hold  to open the controls.

Icon	Name	Description
	Bluetooth	Select to disable Bluetooth® technology and your connection to your paired phone.
	Brightness	Select the slider bar to adjust the screen brightness. Tap and hold to access backlight settings.
	Lock Device	Select to lock the buttons and the touchscreen to prevent inadvertent presses and swipes. You can press the power button to unlock the buttons and touchscreen.
	Power Off	Select to turn off the device.
	Siren	Select to open the siren app and sound an alarm. This control is available only on the inReach® Mini 3 Plus satellite communicator.
	Touch	Select to disable touchscreen controls.
	Volume	Select to mute all device sounds. Tap and hold to open sound settings on the inReach Mini 3 Plus satellite communicator.
	Mark Waypoint	Select to mark a waypoint at your current location with your inReach Mini 3 satellite communicator.

Action Menu

From the home screen, hold BACK to open the action menu.

Name	More Information
Activate Device	Pairs your phone with the Garmin Messenger™ app and activates a service plan (<i>Pairing Your Phone and Activating the Device, page 6</i>).
Start Tracking	Records track points and transmit them over the Iridium® satellite network (<i>Starting Tracking, page 8</i>).
Send Message	Sends a text or post message (<i>Messages, page 9</i>).
Check-In	Sends a check-in message (<i>Sending a Check-In Message, page 9</i>).
Mark Waypoint	Marks a waypoint at your current location (<i>Saving Your Current Location as a Waypoint, page 21</i>).
Navigate	Begins navigating to a destination (<i>Navigation, page 19</i>).
Test Device	Tests your device to ensure your satellite subscription is active (<i>Testing the Device, page 7</i>).
Voice Command	Listens for a voice command on your inReach® Mini 3 Plus satellite communicator (<i>Using Voice Commands, page 16</i>).

Pairing Your Phone and Activating the Device

WARNING

Before you can use the inReach® features of your satellite communicator, including messaging, SOS, tracking, and inReach Weather, you must have an active satellite subscription. You must have a valid, unique phone number that can receive a text message to complete activation and pairing with the Garmin Messenger™ app. VOIP numbers are not supported. Always test your satellite communicator outdoors before using it on a trip.

NOTICE

Some jurisdictions regulate or prohibit the use of satellite communications devices. It is the responsibility of the user to know and follow all applicable laws in the jurisdictions where the device is intended to be used.

The inReach Mini 3 satellite communicator works best when it is paired with the Garmin Messenger app. The app allows you to compose and send messages using your phone, and to sync inReach data with your satellite communicator.

- 1 During the initial setup on your satellite communicator, scan the QR code with the camera on your phone to download and install the Garmin Messenger app.

NOTE: If you previously skipped the pairing process, you can press ▲ or ▼ and select Activation. If you activate the device through the Garmin Explore™ web interface instead of the Garmin Messenger app, voice notes can be sent but not received from your inReach Mini 3 Plus satellite communicator and group messages cannot be sent or received.

- 2 Follow the on-screen instructions to complete the pairing process and activate a subscription service plan.

TIP: To use additional connected features and complete the setup process, download and install the Garmin Explore app using your phone.

After the satellite communicator and phone are paired, they connect automatically when they are turned on and within range.

Garmin Messenger™ App

WARNING

The inReach® features of the Garmin Messenger app on your phone, including SOS, tracking, and inReach Weather, are not available without a connected inReach device and an active inReach service plan. Always test the app outdoors before using it on a trip.

CAUTION

The non-satellite messaging features of the Garmin Messenger app on your phone should not be solely relied upon as a primary method to obtain emergency assistance.

NOTICE

The app works over both the internet (using a wireless connection or cellular data on your phone) and the satellite network. If you are using cellular data, your paired phone must be equipped with a data plan and be in an area of network coverage where data is available. If you are in an area without network coverage, you must have an active inReach service plan for your device to use the satellite network.

You can use the app to message other Garmin Messenger app users, including friends and family without Garmin® devices. Anyone can download the app and connect their phone, allowing them to communicate with other app users over the internet (no login is required). App users can also create group messaging threads with other SMS phone numbers. New members added to the group message can download the app to see what others are saying.

Messages sent using a wireless connection or cellular data on your phone do not incur data charges or additional charges on your inReach service plan. Messages received may incur charges if message delivery is attempted over both the satellite network and the internet. Standard text messaging rates for your cellular data plan apply.

You can download the Garmin Messenger app from the app store on your phone (garmin.com/messengerapp).

Garmin Explore™

The Garmin Explore website and app allow you to create courses, waypoints, and collections, plan trips, sync tracks, upload activities, and use cloud storage. They offer advanced planning both online and offline, allowing you to share and sync data with your compatible Garmin® device. You can use the app to download maps for offline access, and then navigate anywhere without using your cellular service.

You can download the Garmin Explore app from the app store on your phone (garmin.com/exploreapp), or you can go to explore.garmin.com.

Iridium® Satellite Network

Your device requires a clear view of the sky to transmit messages and track points over the Iridium satellite network. Without a clear view of the sky, your device attempts to send the information until it acquires satellite signals.

TIP: For the best connection with satellites, place the device with the antenna pointed toward the sky.

Bluetooth® Connected Features

Your device has several Bluetooth connected features for your compatible phone using the Garmin Explore™ and Garmin Messenger™ apps.

Downloadable Features: View downloaded maps, such as satellite imagery and USGS quadrangle maps on your phone in the Garmin Explore app. You should download maps and charts to your phone in the Garmin Explore before going on your trip.

Sync: The Garmin Messenger app can sync data with your device, such as plan changes, contacts, and messages.

Messages: The Garmin Messenger app allows you to read and write messages and access the contacts list on your phone. Messages appear on both devices.

NOTE: You can have only one phone paired with your inReach® device at a time.

Testing the Device

You should test the device outdoors before using it on a trip to ensure your satellite subscription is active.

1 From the home page, press ▲ or ▼ to scroll through the apps.

2 Select **Service Plan**.

3 Press **OK** to open the options menu.

4 Select **Test Device > Start Test**.

Wait while the device sends a test message. When you receive a confirmation message, your device is ready to use.

inReach® Features

⚠ WARNING

Before you can use the inReach features of your inReach Mini 3 device, including messaging, SOS, tracking, and inReach Weather, you must have an active satellite subscription. Always test your device before you use it outdoors.

Ensure you have a clear view of the sky when using the messaging, tracking, and SOS functions, because these features require satellite access to operate properly.

NOTICE

Some jurisdictions regulate or prohibit the use of satellite communications devices. It is the responsibility of the user to know and follow all applicable laws in the jurisdictions where the device is intended to be used.

inReach® Tracking

You can use the tracking feature on your inReach Mini 3 satellite communicator to record track points and transmit them over the Iridium® satellite network at the specified send interval.

Starting Tracking

- 1 From the home screen, hold **BACK** to open the action menu.
- 2 Select **Start Tracking**.
Starting tracking also starts recording your path as an activity.

Navigating to the Start of Your Current Track

- 1 From the home page, press ▲ or ▼ to scroll through the apps.
- 2 Select **Saved > Current Activity**.
- 3 Scroll down.
- 4 Press **OK** to open the options menu.
- 5 Select **Back to Start**.

Stopping Tracking

- 1 From the home page, press ▲ or ▼ to scroll through the apps.
- 2 Select your current activity timer.
- 3 Scroll down to the last page in the activity loop.
- 4 Press **OK** to open the options menu.
- 5 Select **Stop Tracking**.

Sharing Your Tracking Page

You can share a link to a tracking webpage with other people. The system automatically adds text, including link information, to the end of your message.

- 1 From the home page, press ▲ or ▼ to scroll through the apps.
- 2 Select your current tracking timer.
- 3 Hold **BACK**.
- 4 Select **Send Message**.
- 5 Select recipients from your contacts list, or select **Type Contact** to enter each recipient's contact information.
- 6 Select **Next**.
- 7 Select ☰ > **Tracking Link**.
- 8 Press **BACK**.
- 9 Select the message text to write a custom message (optional).
- 10 When you have finished your message, select ✓.
- 11 Select **Send** to send the message.

Messages

Your inReach® Mini 3 satellite communicator sends and receives messages using the Iridium® satellite network. You can send messages to an SMS phone number, an email address, or another device that uses inReach technology. Each message you send includes your location details where allowed.

Sending a Check-In Message

Check-in messages are messages with predefined text and recipients.

TIP: You can customize check-in message recipients in the Garmin Messenger™ app. From the Device tab in the app, select **Check-In > Edit Check-In Contacts**.

- 1 From the home page, press ▲ or ▼ to scroll through the apps.
- 2 Select **Check-In**.
- 3 Press ▲ or ▼ to scroll through the check-in messages.
- 4 Press **OK** to send a message.

Sending a Text Message

- 1 From the home page, press ▲ or ▼ to scroll through the apps.
- 2 Select **Messenger > New Message**.
- 3 Choose recipients from your contacts list, or select **Type Contact** to enter each recipient's contact information.
- 4 Select **Next > New Message**.
- 5 Select an option:
 - To send a pre-written message, select **Quick Texts** and select a message.
NOTE: You can add and edit quick text messages in the Garmin Messenger™ app.
 - To write a custom message, type your message and select ✓.
- 6 Select  to open the options menu.
- 7 Select an option:
 - To include your current location with your message, select **Message Location**.
 - To include a link to a tracking webpage with your message, select **Tracking Link**.
- 8 Select **Add Voice** to send a voice note with your message (optional).
NOTE: Voice notes are available only on the inReach® Mini 3 Plus satellite communicator and can only be sent to Garmin Messenger accounts.
- 9 When you have finished your message, select **Send**.

Sending a Post Message

You can send a post message to multiple recipients at once, where each recipient receives the message individually without seeing replies from others. Messages sent to more than five contacts, or to email addresses and inReach® addresses, are sent as post messages.

- 1 From the home page, press ▲ or ▼ to scroll through the apps.
- 2 Select **Messenger > New Message**.
- 3 Select a recipient from your contacts list, or select **Type Contact** and enter each recipient's contact information using the keyboard.
- 4 Select **Next**, and select an option:
 - To send a pre-written message, select **Quick Texts** and select a message.
NOTE: You can add and edit quick text messages in the Garmin Messenger™ app.
 - To write a custom message, type your message and select ✓.
- 5 Select **Add Voice** to send a voice note with your message (optional).
Voice notes are available only on the inReach Mini 3 Plus satellite communicator and can only be sent to Garmin Messenger accounts.
- 6 When you have finished your message, select **Send**.

Replying to a Message

- 1 From the home page, press ▲ or ▼ to scroll through the apps.
- 2 Select **Messenger**, and select a conversation.

- 3 Select **Reply**.
- 4 Select an option:
 - To start with a pre-written message, press ▲ or ▼ to scroll through the quick text messages.
 - To write a custom message, select **Type Message**.
- 5 When you have finished your message, select ✓.
- 6 Press **OK** to send the message.

Reacting to a Message

You can react to a message with an emoji.

- 1 From the home page, press ▲ or ▼ to scroll through the apps.
- 2 Select **Messenger**, and select a conversation.
- 3 Select a message.
- 4 Press **OK** to open the options menu.
- 5 Select **React**.
- 6 Select an emoji.

The device sends an emoji reaction to the message.

Downloading Photo and Voice Messages

You can download photo and voice messages if you do not have the automatic download setting turned on ([System Settings, page 24](#)).

- 1 From the **Messenger** app, select a message thread.
- 2 Select the photo or voice message preview.
- 3 Select **Download**.

Checking for Messages

On the inReach® Mini 3 satellite communicator, when you send a message, your device listens for replies for 10 minutes. On the inReach Mini 3 Plus satellite communicator, your device continuously listens for new messages in Performance messaging mode. In Low Power messaging mode, when you send a message, your device listens for replies for 10 minutes. Both the inReach Mini 3 and inReach Mini 3 Plus satellite communicators check for new messages every hour and, when using the inReach tracking feature, check for messages at your tracking interval.

You can force a check for messages by manually checking for messages, sending a message, or sending a track point. During a check, your device connects to satellites and receives messages waiting to be sent to your device.

- 1 From the home page, press ▲ or ▼ to scroll through the apps.
- 2 Select **Messenger**.
- 3 Select ☰ > **Check for Messages**.

Viewing Message Details

- 1 From the home page, press ▲ or ▼ to scroll through the apps.
- 2 Select **Messenger**, and select a conversation.
- 3 Select a message.
- 4 Press **OK** to open the options menu.
- 5 Select **View Details**.

Navigating to a Message Location

When you receive a message from another device with inReach® technology, the message may include location information. For these messages, you can navigate to the location from which the message was sent.

- 1 From the home page, press ▲ or ▼ to scroll through the apps.
- 2 Select **Messenger**, and select a conversation with location information.
- 3 Select a message.
- 4 Press **OK** to open the options menu.
- 5 Select **Navigate**.

Deleting Messages

- 1 From the home page, press ▲ or ▼ to scroll through the apps.
- 2 Select **Messenger**, and select a conversation.
- 3 Select a message.
- 4 Select **Delete**.

Contacts

You can add, delete, and edit contacts for inReach® messages on the inReach Mini 3 satellite communicator.

Adding a Contact

- 1 From the home page, press ▲ or ▼ to scroll through the apps.
- 2 Select **Contacts** > **New Contact**.
- 3 Select an item to edit.
- 4 Enter the new information.

Editing a Contact

- 1 From the home page, press ▲ or ▼ to scroll through the apps.
- 2 Select **Contacts**.
- 3 Select a contact.
- 4 Press **OK** to open the options menu.
- 5 Select **Edit**.
- 6 Select an item to edit.
- 7 Enter the new information.

Deleting a Contact

- 1 From the home page, press ▲ or ▼ to scroll through the apps.
- 2 Select **Contacts**.
- 3 Select a contact.
- 4 Press **OK** to open the options menu.
- 5 Select **Delete**.

SOS

WARNING

Before you can use the SOS function, you must have an active satellite subscription. Always test your device outdoors before using it on a trip.

Ensure you have a clear view of the sky when using the SOS function, because this feature requires satellite access to operate properly.

NOTICE

Some jurisdictions regulate or prohibit the use of satellite communications devices. It is the responsibility of the user to know and follow all applicable laws in the jurisdictions where the device is intended to be used.

During an emergency, you can use your inReach® Mini 3 device to contact the Garmin ResponseSM center to request help. Initiating an SOS rescue sends a message to the Garmin Response team, and they notify the appropriate emergency responders of your situation. You can communicate with the Garmin Response team during your emergency while you wait for help to arrive. You should only use the SOS function in a real emergency situation.

Initiating an SOS Rescue

You can initiate an SOS rescue with the device turned on or off if the device has battery power.

- 1 Lift the protective cap ① from the **SOS** button ②.

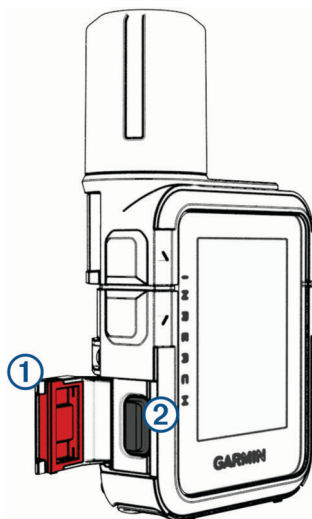

2 Press and hold the **SOS** button.

3 Wait for the SOS countdown.

The device sends a default message to the emergency response service with details about your location.

4 Reply to the confirmation message from the emergency response service.

Your reply lets the emergency response service know that you are capable of interacting with them during the rescue. If you do not reply, the emergency response service will still initiate a rescue.

For the first 10 minutes of your rescue, an updated location is sent to the emergency response service every minute. To conserve battery power after the first 10 minutes, an updated location is sent every 10 minutes.

TIP: You can also initiate an SOS rescue and interact with the Garmin ResponseSM team using the Garmin Messenger™ app. You must have an active satellite subscription to use the SOS feature in the app.

Sending a Custom SOS Message

After pressing the SOS button to initiate an SOS rescue, you can reply with a custom message.

1 From the home page, press ▲ or ▼ to scroll through the apps.

2 Select **SOS > Reply** to compose a custom SOS message.

3 Select an option:

- To start with a pre-written message, press ▲ or ▼ to scroll through the quick text messages.
- To write a custom message, select **Type Message**.

4 When you have finished your message, select ✓.

5 Press **OK** to send the message.

Your reply lets the emergency response service know that you are capable of interacting with them during the rescue.

Canceling an SOS Request

If you no longer need assistance, you can cancel an SOS request after it is sent to the emergency response service.

1 Lift the protective cap, and hold the **SOS** button.

2 Select **Cancel SOS**.

3 When prompted to confirm your cancellation request, select **Cancel SOS**.

Your device transmits the cancellation request. When you receive a confirmation message from the emergency response service, the device returns to normal operation.

Syncing inReach® Data

After you make changes to your data, such as plan changes, contacts, or check-in messages, you must sync your device using the app.

1 Open the paired Garmin Messenger™ app.

2 Wait while your data syncs.

TIP: You can check the connection status on the Device tab in the app.

Viewing Plan Details and Usage

You can view plan details and data use on the inReach® Mini 3 satellite communicator. Data use includes the number of messages, track points, and check-in messages sent during the billing cycle. The data use counters reset automatically at the beginning of each billing cycle.

- 1 From the home page, press ▲ or ▼ to scroll through the apps.
- 2 Select **Service Plan**.
- 3 If you have made changes to your data plan in the Garmin Messenger™ app, select **Update**.

Apps

From the home page, press ▲ or ▼ to scroll through the apps. You can change the order of the apps by tapping and holding an app, and dragging it to a new location.

Name	More Information
Check-In	Select to send a check-in message (Sending a Check-In Message, page 9).
Compass	Select to view the compass (Compass, page 20).
Contacts	Select to manage contacts for inReach® messages (Contacts, page 11).
Garmin Share	Select to send or receive data with other Garmin® devices (Garmin Share, page 14).
inReach Activation	Select to pair your phone and activate a service plan with the Garmin Messenger™ app (Pairing Your Phone and Activating the Device, page 6).
Map	Select to view the map (Map, page 20).
Messenger	Select to send messages over the Iridium® satellite network, and check for new messages (Messages, page 9).
Saved	Select to view your saved waypoints, courses, activities, and collections (Saved Data, page 15).
Service Plan	Select to view details about your inReach service plan (Viewing Plan Details and Usage, page 13).
Settings	Select to open the settings menu (Customizing the Device, page 24).
Siren	Select to sound an alarm. This app is available only on the inReach Mini 3 Plus satellite communicator.
SOS	If an SOS rescue is currently in progress, select to open the SOS message thread (SOS, page 11).
Start Activity	Select to start an activity, record activity points, and send tracking points over the Iridium satellite network (Starting Tracking, page 8).
Voice Command	Select to speak a command for your device to perform (Using Voice Commands, page 16). This app is available only on the inReach Mini 3 Plus satellite communicator.
Voice Notes	Select to record a voice note (Recording a Voice Note, page 16). This app is available only on the inReach Mini 3 Plus satellite communicator.
Weather	Select to view the current weather forecast and conditions (Weather, page 17).

Garmin Share

NOTICE

It is your responsibility to use discretion when sharing information with others. Always ensure you are aware of and comfortable with the individual with whom you share information.

The Garmin Share feature allows you to use Bluetooth® technology to wirelessly share your data with other compatible Garmin® devices. With Garmin Share enabled and compatible Garmin devices in range of each other, you can select saved locations and courses to transfer to another device through a direct, secured device-to-device connection, without the need for a phone or Wi-Fi® connectivity.

Sharing Data with Garmin Share

Before you can use this feature, you must have Bluetooth® technology enabled on both compatible devices, and they must be within 3 m (10 ft.) of each other. When prompted, you must also consent to share your data with other Garmin® devices using Garmin Share.

Your inReach® satellite communicator can send and receive data when connected to another compatible Garmin device ([Receiving Data with Garmin Share, page 15](#)). You can also transfer your data between different devices. For example, you can share a favorite course from your inReach satellite communicator to your compatible Garmin watch.

- 1 From the home page, press ▲ or ▼ to scroll through the apps.
- 2 Select **Garmin Share**.
- 3 Select **Share**.
- 4 Select one or more items.
- 5 Select **Share**.
- 6 Wait while the device locates compatible devices.
- 7 Select a device.

- 8 Confirm the six-digit PIN matches on both devices, and select **Accept**.
- 9 Wait while the devices transfer the data.
- 10 Select **Share Again** to share the same items with another user (optional).
- 11 Select **Done**.

Receiving Data with Garmin Share

Before you can use this feature, you must have Bluetooth® technology enabled on both compatible devices, and they must be within 3 m (10 ft.) of each other. When prompted, you must also consent to share your data with other Garmin® devices using Garmin Share.

- 1 From the home page, press ▲ or ▼ to scroll through the apps.
- 2 Select **Garmin Share**.
- 3 Wait while the device locates compatible devices in range.
- 4 Select **Accept**.
- 5 Confirm the six-digit PIN matches on both devices, and select **Accept**.
- 6 Wait while the devices transfer the data.
- 7 Select **Done**.

Saved Data

From the home page, select **Saved**.

Waypoints: Waypoints are locations you record and store in the device. Waypoints can mark where you are, where you are going, or where you have been ([Waypoints](#), page 21).

Courses: A course is a sequence of waypoints or locations that leads you to your final destination ([Courses](#), page 22).

Activities: You can use your device to record your path as an activity ([Starting an Activity](#), page 22).

Collections: You can use the Garmin Explore™ app to group related waypoints, courses, or activities into collections ([Garmin Explore™](#), page 7).

Using the Saved App

- 1 From the home page, press ▲ or ▼ to scroll through the apps.
- 2 Select **Saved**.
Saved items from your device and collections synced from your Garmin Explore™ account appear.
- 3 Select a category, and select a saved item.
- 4 Select an option:
Not all options are available for all types of saved items.
 - To navigate to a saved item, select **Navigate**.
 - To reverse a course, press ▼ and select ☰ > **Reverse Course**.
 - To delete a saved item, press ▼ and select ☰ > **Delete**.
 - To edit a waypoint, press ▼ and select ☰ > **Edit Details**.
 - To navigate back to the start of an activity, press ▼ and select ☰ > **Back to Start**.

Viewing Saved Data

- 1 From the home page, press ▲ or ▼ to scroll through the apps.
- 2 Select **Saved**.
- 3 Select a saved item.
- 4 Select **View Details** or **View on Map**.

Deleting Saved Data

- 1 From the home page, press ▲ or ▼ to scroll through the apps.
- 2 Select **Saved**.
- 3 Select a saved item.
- 4 Scroll up or down.
- 5 Press **OK** to open the options menu.
- 6 Select **Delete**.

Using Voice Commands

You can use the integrated microphone in your inReach® Mini 3 Plus satellite communicator to say a command for the device to perform.

NOTE: Voice command is not available for all languages and regions.

- 1 Hold **OK**.
- 2 Say a voice command ([Voice Commands, page 16](#)).

Voice Commands

The voice command system is designed to detect natural speech. This is a list of commonly used voice commands, but the inReach® Mini 3 Plus satellite communicator does not require these exact phrases. You can try saying variations of these commands in a way that is natural to you.

Voice Help Command	Function
What can I say?	Shows a list of common voice commands.

Device and Screen Functions

Voice Command	Function
Increase brightness	Raises the screen brightness level.

App and Activity Functions

Voice Command	Function
Show me the weather	Example of a command to open an app on the device. For example, this one opens the weather app.
Switch to the compass app	Example of a command to open an app on the device. For example, this one opens the compass.
Start activity	Starts recording an activity.
Start tracking	Starts inReach tracking.

NOTE: The apps listed are examples, but you can control all of the default apps and activities with voice commands ([Apps, page 14](#)).

Navigation Functions

Voice Command	Function
Begin navigation	Opens the search menu to search for a destination.
Save location	Saves your current location.

Media Functions

Voice Command	Function
Change volume to 8	Adjusts the volume to the specified level. Available numbers are 10-100.
Decrease volume	Lowers the audio volume.
Mute	Silences all audio.





Voice Command Tips

- Speak in a normal voice directed at the microphone.
- Use phrases that the device can recognize ([Voice Commands, page 16](#)).
- Reduce background noise, such as voices or wind, to increase the accuracy of the voice recognition.
- Hold the device close to your mouth with your back to strong winds for best performance.

Recording a Voice Note

You can record and listen to voice notes using the built-in speaker and microphone in your inReach® Mini 3 Plus device.

- 1 From the home page, press ▲ or ▼ to scroll through the apps.
- 2 Select **Voice Notes > New Voice Note**.
- 3 Press **OK** or select ● to begin recording.
- 4 Say your voice note.

- 5 Press **OK** or select  to stop recording.
- 6 Select an option:
 - Select  to play the voice note.
 - Select  and select **Rename** to rename the voice note.
 - Select  and select **Volume** to adjust the playback volume
 - Select  and select **Delete** to delete the voice note.



Weather

WARNING

Before you can use the inReach® features of your satellite communicator, including messaging, SOS, tracking, and inReach Weather, you must have an active satellite subscription. You must have a valid, unique phone number that can receive a text message to complete activation and pairing with the Garmin Messenger™ app. VOIP numbers are not supported. Always test your satellite communicator outdoors before using it on a trip.

Viewing a Weather Forecast



While your inReach® satellite communicator is connected to your phone and has an active data connection, it can receive detailed weather information from the internet.

- 1 From the home page, press  or  to scroll through the apps.
- 2 Select **Weather**.



The satellite communicator automatically downloads a weather forecast for your current location.
- 3 Select a time interval or a day to view detailed weather information.

Adding a Waypoint as a Weather Location

You can add a saved waypoint as a weather location ([Waypoints, page 21](#)).



- 1 From the home page, press  or  to scroll through the apps.
- 2 Select **Weather**.
- 3 Press **OK** to open the options menu.
- 4 Select **Change Location > Edit > New Location**.
- 5 Select a waypoint.

Setting the Weather Location

- 1 From the home page, press  or  to scroll through the apps.
- 2 Select **Weather**.
- 3 Press **OK** to open the options menu.
- 4 Select **Change Location**.
- 5 Select an option:
 - To set your current location, select **My Location**.
 - To set a previously used location, select the location from the list.
 - To add a location, select **Edit > New Location**.

Requesting an inReach® Weather Forecast

While your inReach Mini 3 satellite communicator is connected to your phone and has an active internet connection, it can receive detailed weather information from the internet. If you are in a location without active internet access, your inReach Mini 3 satellite communicator can send a message to request a weather forecast using your inReach service plan. You can receive weather forecasts for your current location, a waypoint, GPS coordinates, or a location you choose on the map. Weather forecasts incur data charges or additional charges on your inReach service plan. For the best results, you should ensure your satellite communicator has a clear view of the sky when you request a weather forecast over satellite.

- 1 From the home page, press  or  to scroll through the apps.
- 2 Select **Weather**.
- 3 Press **OK** to open the options menu.
- 4 Select **Update**.

The device sends a request for the forecast. It may take several minutes to receive the weather forecast data.

NOTE: A marine forecast will be included for locations on an ocean or other large body of water, if available. If you are unable to get a marine forecast, select a location further from the shore.

After the device finishes downloading the data, you can view the forecast at any time until all of the information in the forecast has expired. You can also update the forecast at any time.

NOTE: Updating a forecast incurs data charges or additional usage charges.

Updating an inReach® Weather Forecast

You can update an inReach weather forecast that has expired or contains outdated information. Updating a forecast incurs the same data charges or additional charges as requesting a forecast.

NOTE: When your inReach Mini 3 satellite communicator is connected to the internet through the Garmin Explore™ app, weather forecasts are updated automatically and do not incur an additional charge. A manual update option is not available.

- 1 From the home page, press ▲ or ▼ to scroll through the apps.
- 2 Select **Weather**.
- 3 Press **OK** to open the options menu.
- 4 Select **Update**.

The device requests an updated forecast. If you update the My Location forecast, the device requests an updated forecast for your current location. It may take several minutes to receive the updated weather forecast data.

Deleting a Weather Location

You must set the weather location before you can delete it ([Setting the Weather Location, page 17](#)).

You can delete an expired forecast or a forecast for a location that you no longer need.

- 1 From the home page, press ▲ or ▼ to scroll through the apps.
- 2 Select **Weather**.
- 3 Press **OK** to open the options menu.
- 4 Select **Change Location > Edit > Select a Location > **.

Navigation

Acquiring GPS Satellite Signals

Before you can use GPS navigation features, you must acquire satellite signals.

When you turn on your navigation device, the GPS receiver must collect satellite data and establish the current location. The time required to acquire satellite signals varies based on several factors, including how far you are from the location where you last used your navigation device, whether you have a clear view of the sky, and how long it has been since you last used your navigation device. The first time you turn on your navigation device, it may take several minutes to acquire satellite signals.

- 1 Turn on the device.
- 2 Open the map or start an activity.
- 3 Wait while the device locates satellites.
It may take up to 60 seconds to acquire satellite signals.
- 4 If necessary, go to an open area, away from tall buildings and trees.

Panning and Zooming the Map

- 1 From the home page, press ▲ or ▼ to scroll through the apps.
- 2 Select **Map**.
- 3 Press **OK** to open the options menu.
- 4 Select **Pan/Zoom**.
- 5 Select an option:
 - To toggle between panning up and down, panning left and right, or zooming, press **OK**.
 - Drag the map, or press ▲ or ▼ to view different areas.
 - Pinch or spread two fingers on the touchscreen, or press + and - to zoom in and out on the map.
TIP: You can double-tap the map to quickly zoom in.
 - To quit, press **BACK** twice.

Navigating Using TracBack®

While recording an activity, you can navigate back to the beginning of your path.

NOTE: This can be helpful if you get lost and need to find your way back to camp or the trail head.

- 1 From the home screen, hold **BACK** to open the action menu.
- 2 Select **Navigate > TracBack**.
- 3 Select **Edit TracBack**.
- 4 Select the destination, and select the time interval.
- 5 Press ▼ to scroll through the recorded points.
- 6 Press **OK** to select a point to navigate to.
- 7 Select the **Direct Path** toggle to take the most direct path back to start.
- 8 Press **BACK**.
- 9 Select **Navigate > Start** to start navigating.

Navigating to Known Coordinates

- 1 From the home screen, hold **BACK** to open the action menu.
- 2 Select **Navigate > Coordinates**.
- 3 Enter the coordinates.
- 4 Press **OK** to start navigation.

Viewing Your Current Coordinates

- 1 From the home screen, hold **BACK** to open the action menu.
- 2 Select **Navigate > Coordinates**.
- 3 Your current coordinates appear.

Navigating with Sight 'N Go

You can point the device at an object in the distance, lock in the direction, and navigate to the object.

- 1 From the home screen, hold **BACK** to open the action menu.
- 2 Select **Navigate > Sight 'N Go**.
- 3 Point the device at an object.
- 4 Press **OK** to start navigation.

Stopping Navigation

- 1 From the home screen, hold **BACK** to open the action menu.
- 2 Select **Stop Navigation**.

Compass

Navigating with the Compass

When navigating to a destination, ▲ points to your destination, regardless of the direction you are moving. When ▲ points toward the top of the electronic compass, you are traveling directly toward your destination. If ▲ points any other direction, turn until it points toward the top of the compass.

- 1 Begin navigating to a destination ([Navigation, page 19](#)).
- 2 From the navigation page, turn until ▲ points toward the top of the compass, and continue moving in that direction to the destination.

Calibrating the Compass

NOTICE

Calibrate the electronic compass outdoors. To improve heading accuracy, do not stand near objects that influence magnetic fields, such as vehicles, buildings, and overhead power lines.

If you experience irregular compass behavior, for example, after moving long distances or after extreme temperature changes, you can manually calibrate the compass.

- 1 From the home page, press ▲ or ▼ to scroll through the apps.
- 2 Select **Compass**.
- 3 Press **OK** to open the options menu.
- 4 Select **Calibrate**.
- 5 Follow the on-screen instructions.

Setting the Compass Heading

- 1 From the home page, press ▲ or ▼ to scroll through the apps.
- 2 Select **Compass**.
- 3 Press **OK** to open the options menu.
- 4 Select **Lock Heading**.
- 5 Point the top of the device toward your heading, and select **Lock Heading**.
When you deviate from the heading, the compass displays the direction from the heading and the degree of deviation.

Compass Settings

From the home page, press ▲ or ▼ to scroll through the apps, select **Compass**, and select  > **Settings**.

Bearing: Sets the directional reference.

Map

▲ represents your location on the map. As you travel, ▲ moves and displays your path. Depending on your zoom level, waypoint names and symbols may appear on the map. You can zoom in on the map to see more detail. When you are navigating to a destination, your route is marked with a colored line on the map.

Changing the Map Orientation

- 1 From the home page, press ▲ or ▼ to scroll through the apps.
- 2 Select **Map**.
- 3 Press **OK** to open the options menu.

- 4 Select **Orientation**.
- 5 Select an option:
 - Select **North Up** to show north at the top of the map.
 - Select **Track Up** to show your current direction of travel at the top of the map.

Waypoints

Waypoints are locations you record and store in the device. Waypoints can mark where you are, where you are going, or where you have been.

Saving Your Current Location as a Waypoint

- 1 From the home screen, hold **BACK** to open the action menu.
- 2 Select **Mark Waypoint**.

Saving a Message Location as a Waypoint

When you send a message or when you receive a message from another device with inReach® technology, the message may include location information. For these messages, you can save the location from which the message was sent as a waypoint.

- 1 From the home page, press ▲ or ▼ to scroll through the apps.
- 2 Select **Messenger**, and select a conversation with location information.
- 3 Select a message.
- 4 Press **OK** to open the options menu.
- 5 Select **View on Map**.
- 6 Scroll down to the coordinates page.
- 7 Press **OK** to open the options menu.
- 8 Select **Mark Waypoint**.

Saving a Location on the Map as a Waypoint

You can save a location on the map as a waypoint.

- 1 From the home page, press ▲ or ▼ to scroll through the apps.
- 2 Select **Map**.
- 3 Select an option:
 - Tap the screen to select a location.
 - Press **OK**, select **Pan/Zoom**, move the cursor to a location, and press **BACK**.
- 4 Press **OK**.
- 5 Select **Mark Waypoint**.

Navigating to a Waypoint

- 1 From the home screen, hold **BACK** to open the action menu.
- 2 Select **Navigate > Saved > [Waypoint Icon] > Waypoints**.
- 3 Select a waypoint.
- 4 Select **Navigate > Start**.

Editing a Waypoint

- 1 From the home page, press ▲ or ▼ to scroll through the apps.
- 2 Select **Saved > [Waypoint Icon] > Waypoints**.
- 3 Select a waypoint.
- 4 Scroll up or down.
- 5 Press **OK** to open the options menu.
- 6 Select **Edit Details**.
- 7 Select an option:
 - To change the name of the waypoint, select **Name**.
 - To change the symbol representing the waypoint, select **Icon**.
 - To change the GPS coordinates of the waypoint, select **Position**.
- 8 Enter the new information.

Deleting a Waypoint

- 1 From the home page, press ▲ or ▼ to scroll through the apps.
- 2 Select **Saved** >  > **Waypoints**.
- 3 Select a saved waypoint.
- 4 Scroll up or down from the map.
- 5 Press **OK** to open the options menu.
- 6 Select **Delete**.

Courses

A course can have multiple destinations, and can be navigated point to point or on routable roads. You can create and save courses in the Garmin Explore™ app.

Navigating a Saved Course

- 1 From the home screen, hold **BACK** to open the action menu.
- 2 Select **Navigate** > **Saved** >  > **Courses**.
- 3 Select a course.
- 4 Press **OK** to open the options menu.
- 5 Select **Go**.

Reversing a Course

You can switch the start and end points of your course to navigate in reverse.

- 1 From the home screen, hold **BACK** to open the action menu.
- 2 Select **Navigate** > **Saved** >  > **Courses**.
- 3 Select a course.
- 4 Scroll down.
- 5 Press **OK** to open the options menu.
- 6 Select **Reverse Course**.

Activities

While tracking, your device records your path as an activity. You can view details about your activity, including distance and time, and view the path of your activity on a map.

Starting an Activity

You can use the Start Activity feature to select your activity options and hit the trail quickly. Your device remembers your selections and saves them for the next time you start an activity.

- 1 From the home screen, select **Start Activity**.
- 2 Select your activity options:
 - Select **Tracking**, and turn on the toggle switch to enable inReach® tracking when you start your activity.
 - Select **Tracking** > **Send Interval** to set the frequency at which the device records a track point and transmits it over the satellite network when you are moving.
 - Select **Navigation** to begin navigating to a destination ([Navigation, page 19](#)).
 - Select **High Detail** to log your location and update the track line more frequently in the device memory than the default setting.
 - Select **Auto Start** to set the device to start an activity recording when you turn it on or after a previous activity is saved or discarded.
 - Select **Activity** to select an activity type.
 - Select **Track Color** to change the track log color.
- 3 Go outdoors to an open area.
- 4 Select **Start**, and wait while the device locates satellites.
The device begins recording your path as part of the activity.

Customizing the Current Activity

- 1 While you are recording an activity, select the current activity, and select  > **Activity Controls**.
- 2 Select an option:

- To turn inReach® tracking on or off, select **Tracking**.
- To navigate to a destination, select **Navigation**.
- To log your location and update the track line more frequently than the default, select **High Detail**.
- To set the device to start an activity recording when you turn it on or after a previous activity is saved or discarded, select **Auto Start**.
- To select an activity type, select **Activity**.
- To set the color of the track on the map, select **Track Color**.

Viewing the Current Activity

When you start tracking, your device starts recording your path as an activity ([Starting Tracking, page 8](#)).

- 1 From the home page, press ▲ or ▼ to scroll through the apps.
- 2 Select **Saved > Current Activity**.
- 3 Scroll up or down to view activity details.

Navigating a Saved Activity

- 1 From the home page, press ▲ or ▼ to scroll through the apps.
- 2 Select **Saved >  > Activities**.
- 3 Select an activity.
- 4 Select **Navigate > Start**.

Stopping the Current Activity

- 1 While you are recording an activity, select the current activity from the home screen, and select  > **Activity Controls**.
- 2 Select **Stop**.
- 3 Select an option:
 - To resume the current activity, select **Resume**.
 - To save the activity, select **Save**.
 - To navigate back to the beginning of your activity, select **TracBack** ([Navigating Using TracBack®, page 19](#)).
 - To discard the activity, select **Discard**.

Customizing the Device

Sounds Settings

From the home page, press ▲ or ▼ to scroll through the apps. Select **Settings > Sounds**.

Mute All: Mutes all device tones.

Volume: Sets the device volume level.

Message Rec.: Sets the tone that sounds when you receive a message.

Message Sent: Sets the tone that sounds when the you send a message.

Critical Alert: Sets the tone that sounds when the device announces a critical alert.

Ring Until Read: Sets the device to ring until you read a new message. This feature is helpful if you are in a noisy environment.

Phone Settings

From the home page, press ▲ or ▼ to scroll through the apps. Select **Settings > Phone**.

Status: Enables Bluetooth® wireless technology.

Pair Phone: Pairs your device with a compatible Bluetooth enabled smartphone. This setting allows you to use Bluetooth connected features using the Garmin Explore™ app or Garmin Messenger™ app.

inReach Remote Settings

You can use some inReach® Mini 3/3 Plus features using another compatible device with ANT® wireless technology, such as the fēnix® watch. You can use the inReach Remote option to view incoming messages, send check-in messages, start and stop tracking, and initiate or cancel an SOS.

From the home page, press ▲ or ▼ to scroll through the apps. Select **Settings > inReach Remote**.

Status: Turns on or off the inReach Remote feature and allows you to access some inReach features using another compatible device.

Device Number: Displays the device number for the ANT channel.

Verified Devices: Displays a list of verified devices that this device can wirelessly connect to.

Tracking Settings

From the home page, press ▲ or ▼ to scroll through the apps. Select **Settings > Tracking**.

Send Interval: Sets the frequency at which the device records a track point and transmits it over the satellite network.

NOTE: The Send Interval frequency affects battery life ([Battery Information, page 27](#)).

Activity Recording: Sets the level of detail used in your activity recording. The High Detail option logs your location and updates the track line more frequently in the device memory than the Standard option.

NOTE: Higher detail recordings decrease battery life ([Battery Information, page 27](#)).

Auto Start: Sets the device to start tracking when you turn on the device.

Map Settings

From the home page, press ▲ or ▼ to scroll through the apps. Select **Settings > Map**.

Waypoints: Shows or hides waypoints on the map.

Waypoint Labels: Shows or hides waypoint labels on the map.

Tracking Points: Shows or hides tracking points on the map.

Messages: Shows or hides messages on the map.

Auto Zoom: Automatically sets the zoom level for optimal use of your map. When Off is selected, you must zoom in or out manually.

Orientation: Sets the orientation of the map. The North Up option shows north at the top of the screen. The Track Up option shows your current direction of travel at the top of the screen.

System Settings

From the home page, press ▲ or ▼ to scroll through the apps. Select **Settings > System**.

Display & Brightness: Sets the backlight brightness and the length of time before the backlight turns off.

Language: Sets the text language on the device.

NOTE: Changing the text language does not change the language of user-entered data or map data.

Keyboard Language: Enables keyboard languages.

Default Keyboard: Sets the default keyboard type.

Passcode: Sets a four-digit passcode to secure your device ([Setting Your Device Passcode, page 26](#)).

Compass Cal.: Calibrates the compass ([Calibrating the Compass, page 20](#)).

Time: Sets the time format and time zone ([Time Settings, page 25](#)).

Units: Sets the position format and units of measure for the device ([Units Settings, page 25](#)).

Auto Download Photo & Voice Messages: Sets the device to automatically download photo and voice messages.

NOTE: This option is available only on your inReach® Mini 3 Plus satellite communicator.

Messaging Mode: Performance mode listens continuously for incoming inReach messages, which reduces battery life. Low Power mode extends battery life by checking for incoming inReach messages less frequently ([Battery Information, page 27](#)).

NOTE: This option is available only on your inReach Mini 3 Plus satellite communicator.

Satellite: Sets the satellite system options ([Satellite Settings, page 25](#)).

USB Mode: Sets the device to use mass storage mode or Garmin® mode when connected to a computer.

External Power: Automatically turns off the device when it is disconnected from external power.

Reset: Resets user data and settings ([Resetting All Default Settings, page 30](#)).

Software Update: Installs software updates downloaded to your device.

About: Displays the IMEI number, authorization code, software, license, and regulatory information.

Time Settings

From the home page, press ▲ or ▼ to scroll through the apps. Select **Settings > System > Time**.

Time Format: Sets the device to show time in a 12-hour or 24-hour format.

Time Zone: Sets the time zone for the device.

Daylight Saving: Sets the device to use daylight saving time. This option is not available when Time Zone is set to Automatic.

Units Settings

From the home page, press ▲ or ▼ to scroll through the apps. Select **Settings > System > Units**.

Position Format: Sets the format used for geographical position coordinates and the coordinate system used by the map ([Position Format Settings, page 25](#)).

Speed/Distance: Sets the unit of measure for distance.

Wind Speed: Sets the unit of measure for wind speed.

Temperature: Sets the temperature unit of measure to Fahrenheit (°F) or Celsius (°C).

Bearing: Sets the north reference used on the compass to true or magnetic north.

Position Format Settings

NOTE: You should not change the position format or the map datum coordinate system unless you are using a map or chart that specifies a different position format.

From the home page, press ▲ or ▼ to scroll through the apps. Select **Settings > System > Units > Position Format**.

Format: Sets the position format in which a location reading appears.

Datum: Sets the coordinate system on which the map is structured.

Spheroid: Shows the coordinate system the device is using. The default coordinate system is WGS 84.

Satellite Settings

You can change the satellite systems used by the device. For more information about satellite systems, go to garmin.com/aboutGPS.

From the home page, press ▲ or ▼ to scroll through the apps. Select **Settings > System > Satellite**.

GPS Only: Enables the GPS satellite system.

Multi-GNSS: Enables multiple satellite systems. Using multiple satellite systems together offers increased performance in challenging environments and faster position acquisition than using GPS only. However, using multiple systems can reduce battery life more quickly than using GPS only.

All + Multi-Band: Enables multiple satellite systems on multiple frequency bands. Multi-band systems use multiple frequency bands and allow for more consistent track logs, improved positioning, improved multi-

path errors, and fewer atmospheric errors when using the device in challenging environments. However, using multiple systems can reduce battery life more quickly than using GPS only.

Setting Your Device Passcode

NOTICE

If you enter your passcode incorrectly three times, the device locks temporarily. After five incorrect attempts, the device locks until you reset your passcode in the Garmin Messenger™ app. If you have not paired your device with your phone, the device deletes your data and resets to the factory default settings after five incorrect attempts.

You can set up a device passcode to prevent unauthorized users from using your device.

1 Select an option:

- During the initial setup, select **Create Passcode** when prompted.
- Press ▲ or ▼ to scroll through the apps list, and select **Settings > System > Passcode > Set Passcode**.

2 Enter a four-digit passcode.

3 Re-enter the passcode.

By default, you must enter the passcode immediately after you turn on the device or when the screen turns back on. You can set a time interval before a passcode is required using the Require Passcode setting.

Device Information

Product Updates

On your computer, install Garmin Express™ (www.garmin.com/express). On your phone, install the Garmin Explore™ app.

This provides easy access to these services for Garmin® devices:

- Software updates
- Data uploads to Garmin Explore
- Product registration

Setting Up Garmin Express™

- 1 Connect the device to your computer using a USB cable.
- 2 Go to garmin.com/express.
- 3 Follow the on-screen instructions.

Getting More Information

You can find more information about this product on the Garmin® website.

- Go to support.garmin.com for additional manuals, articles, and software updates.
- Go to buy.garmin.com, or contact your Garmin dealer for information about optional accessories and replacement parts.

Specifications

Battery type	Rechargeable, built-in lithium-ion battery
Battery capacity	1800 mAh
Water rating	IEC 60529 IP67 ¹
Operating temperature range	From -20° to 60°C (from -4° to 140°F)
Charging temperature range	From -20° to 0°C (from -4° to 32°F) - Slow charging to full capacity From 0° to 45°C (from 32° to 113°F) - Full speed charging to full capacity From 45° to 60°C (from 113° to 140°F) - Full speed charging to reduced capacity
Wireless frequency	2400 - 2483,5 MHz < 13dBm 1610 - 1626,5 MHz < -3 dBW/4 KHz
EU SAR (limb)	inReach® Mini 3 Plus 0.73 W/kg simultaneous inReach Mini 3 0.85 W/kg simultaneous
EU SAR (body)	inReach Mini 3 Plus 0.73 W/kg simultaneous inReach Mini 3 0.85 W/kg simultaneous

Battery Information

The actual battery life depends on your device settings and if you are recording a high detail activity or tracking at a high interval. For optimal battery life, ensure you have a clear view of the sky.

inReach® Mini 3

Mode	Battery Life
10-minute tracking send interval	Up to 350 hours
10-minute tracking send interval and high detail activity recording (GPS mode)	Up to 170 hours
10-minute tracking send interval and high detail activity recording (all satellite systems mode)	Up to 120 hours
2-minute tracking send interval	Up to 105 hours
Turned off	Up to 1 year

¹ The device is protected against the ingress of dust and withstands incidental exposure to water of up to 1 m for up to 30 min.

inReach Mini 3 Plus

Mode	Battery Life
Low power messaging mode with 10-minute tracking send interval	Up to 350 hours
Performance messaging mode with 10-minute tracking send interval	Up to 95 hours
Performance messaging mode with 10-minute tracking send interval and high detail activity recording (GPS mode)	Up to 75 hours
Performance messaging mode with 10-minute tracking send interval and high detail activity recording (all satellite systems mode)	Up to 60 hours
Performance messaging mode 2-minute tracking send interval	Up to 55 hours
Turned off	Up to 1 year

Viewing E-Label Regulatory and Compliance Information

The label for this device is provided electronically. The e-label may provide regulatory information, such as identification numbers provided by the FCC or regional compliance markings, the IMEI number, as well as applicable product and licensing information.

- 1 From the main menu, select **Settings**.
- 2 Select **System**.
- 3 Select **About**.

Attaching the Spine Mount Adapter

- 1 Slide the spine mount adapter clip into the tether loop on top of the device.



- 2 Using a T10 TORX screwdriver, secure the spine mount adapter over the back of the device using the screw included with the adapter.

Attaching the Carabiner Tether

- 1 Insert the loop of the tether through the slot in the device.

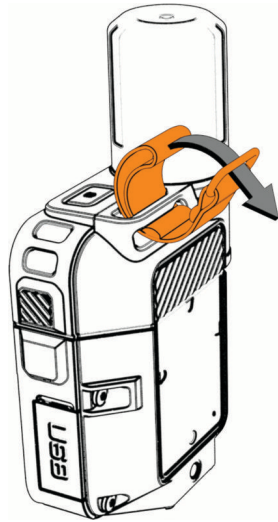

- 2 Thread the other end of the tether through the loop, and pull it tight.
- 3 Thread the ring through the top of the tether.
- 4 Clip a carabiner through the ring.

Attaching a Lanyard

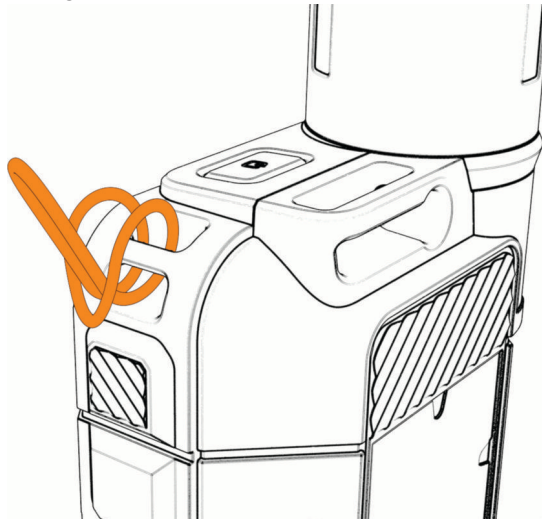

- 1 Insert the loop of the lanyard through the slot in the device.



- 2 Thread the other end of the lanyard through the loop, and pull it tight.
- 3 If necessary, attach the lanyard to your clothing or backpack to tether it during an activity.





Locking and Unlocking the Device

You can lock the buttons and touchscreen to prevent accidental button presses and swipes.

- 1 Hold .
- 2 Select  to lock the device.
- 3 Press  to unlock the device.

Locking and Unlocking the Touchscreen

You can lock the screen to prevent inadvertent screen touches.

- 1 Hold , and select  to lock the touchscreen.
- 2 Hold , press  until you select , and press **OK** to unlock the touchscreen.

Capturing a Screenshot

Hold  and **OK**.

A message appears to confirm the screenshot was captured.
The picture file is saved in the Garmin® > ScreenShot folder on the device drive.

Device Care

NOTICE

Do not store the device where prolonged exposure to extreme temperatures can occur, because it can cause permanent damage.

Never use a hard or sharp object to operate the touchscreen, or damage may result.

Avoid chemical cleaners, solvents, sunscreen, and insect repellents that can damage plastic components and finishes.

Secure the weather cap tightly to prevent damage to the USB port.

Avoid extreme shock and harsh treatment, because it can degrade the life of the product.

Cleaning the Device

- 1 Wipe the device using a cloth dampened with a mild detergent solution.
- 2 Wipe it dry.

Cleaning the USB Port

- 1 Turn off the device and disconnect the device from power.
- 2 Clean the USB port using a soft, clean, lint-free cloth or cotton swab.
NOTE: If necessary, you can lightly dampen the cloth or cotton swab with isopropyl alcohol.
- 3 Allow the device to dry completely before you connect it to power.

Cleaning the Touchscreen

- 1 Use a soft, clean, lint-free cloth.
- 2 If necessary, lightly dampen the cloth with water.
- 3 If using a dampened cloth, turn off the device and disconnect the device from power.
- 4 Gently wipe the screen with the cloth.



Troubleshooting

Maximizing Battery Life

- Reduce the backlight timeout and brightness (*System Settings, page 24*).
- Reduce the frequency of the tracking **Send Interval** setting (*Tracking Settings, page 24*).
- Use the **Standard** level of detail for activity recordings (*Tracking Settings, page 24*).
- Turn off Bluetooth® technology (*Phone Settings, page 24*).
- Use **Low Power** messaging mode on your satellite communicator (*System Settings, page 24*).
- Turn off additional satellite systems (*Satellite Settings, page 25*).

My device is in the wrong language

You can change the device language selection if you have accidentally selected the wrong language on the device.

- 1 From the home page, scroll down and select .
- 2 Scroll down, and select .
- 3 Select the second item in the list.
- 4 Select your language.

Resetting All Default Settings

Before you reset your device, you should sync your device with the Garmin Explore™ app to upload your activity data.

You can reset all device settings to the factory default values.

- 1 From the home page, press ▲ or ▼ to scroll through the apps.
- 2 Select **Settings > System > Reset**.
- 3 Select an option:

- To reset all of the device settings to the factory default values and save all user-entered information and activity history, select **Reset Default Settings**.
- To delete all of the messages on the device, select **Delete All Messages**.
- To reset all of the device settings to the factory default values and delete all user-entered information and activity history, select **Delete Data and Reset Settings**.

Charging the inReach® Device

NOTICE

To prevent corrosion, thoroughly dry the USB port, the weather cap, and the surrounding area before charging or connecting to a computer.

NOTE: The device does not charge when it is outside the approved temperature range (*Specifications, page 27*).

- 1 Lift the weather cap ①.

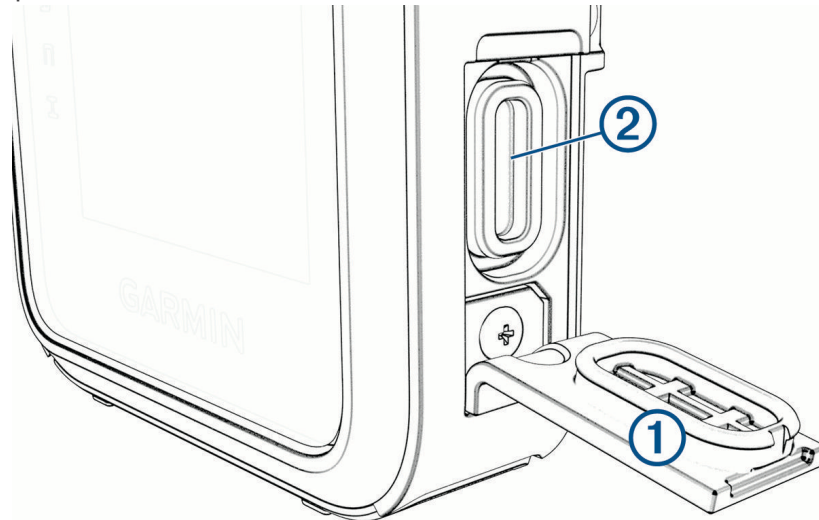

- 2 Plug the power cable into the charging port ② on the device.
- 3 Plug the other end of the power cable into a compatible AC power adapter.
- 4 Plug the AC power adapter into a standard wall outlet.
The device displays the current battery charge level.

Saving Energy While Charging the Device

- 1 Connect your device to an external power source.
- 2 Hold the power button until the screen turns off.
The device goes into a low power, battery charging mode, and the battery gauge appears.
NOTE: If the charging source is not providing sufficient power, you can turn the device off while charging by holding the power button until  appears.
- 3 Charge the device completely.

support.garmin.com

© 2025 Garmin Ltd. or its subsidiaries

Garmin®, the Garmin logo, ANT®, fēnix®, inReach®, and TracBack® are trademarks of Garmin Ltd. or its subsidiaries, registered in the USA and other countries. Garmin Explore™, Garmin Express™, Garmin Messenger™, and Garmin Response™ are trademarks of Garmin Ltd. or its subsidiaries. These trademarks may not be used without the express permission of Garmin.

The Bluetooth® word mark and logos are owned by the Bluetooth SIG, Inc. and any use of such marks by Garmin is under license. Iridium® is a registered trademark of Iridium Satellite LLC. TORX® is a registered trademark of Acument Intellectual Properties, LLC in the United States or other countries. Other trademarks and trade names are those of their respective owners.

