

GARMIN.

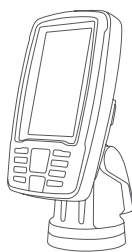

ECHOMAP™ PLUS 40 SERIES INSTALLATION INSTRUCTIONS

Important Safety Information

WARNING

See the *Important Safety and Product Information* guide in the product box for product warnings and other important information.

When connecting the power cable, do not remove the in-line fuse holder. To prevent the possibility of injury or product damage caused by fire or overheating, the appropriate fuse must be in place as indicated in the product specifications. In addition, connecting the power cable without the appropriate fuse in place voids the product warranty.

CAUTION

Always wear safety goggles, ear protection, and a dust mask when drilling, cutting, or sanding.

NOTICE

When drilling or cutting, always check what is on the opposite side of the surface.

To obtain the best performance and to avoid damage to your boat, install the device according to these instructions.

Read all installation instructions before proceeding with the installation. If you experience difficulty during the installation, contact Garmin® Product Support.

Software Update

You may need to update the device software when you install the device or add an accessory to the device.

This device supports up to a 32 GB memory card, formatted to FAT32.

Loading the New Software on a Memory Card

You must copy the software update to a memory card using a computer that is running Windows® software.

NOTE: You can contact Garmin customer support to order a preloaded software update card if you do not have a computer with Windows software.

- 1 Insert a memory card into the card slot on the computer.
- 2 Go to www.garmin.com/support/software/marine.html.
- 3 Select **echoMAP Series with SD Card**.
- 4 Select **Download** next to **echoMAP Series with SD Card**.
- 5 Read and agree to the terms.
- 6 Select **Download**.
- 7 Choose a location, and select **Save**.

- 8 Double-click the downloaded file.
- 9 Select **Next**.
- 10 Select the drive associated with the memory card, and select **Next > Finish**.

A Garmin folder containing the software update is created on the memory card. The software update can take several minutes to load onto the memory card.

Updating the Device Software

Before you can update the software, you must obtain a software-update memory card or load the latest software onto a memory card.

- 1 Turn on the chartplotter.
- 2 After the home screen appears, insert the memory card into the card slot.
NOTE: In order for the software update instructions to appear, the device must be fully booted before the card is inserted.
- 3 Follow the on-screen instructions.
- 4 Wait several minutes while the software update process completes.
- 5 When prompted, leave the memory card in place and restart the chartplotter manually.
- 6 Remove the memory card.
NOTE: If the memory card is removed before the device restarts fully, the software update is not complete.

Tools Needed

- Drill
- Drill bits
 - Bail mount: drill bits appropriate for the surface and hardware
 - Swivel mount: 3 mm (1/8 in.) drill bit
 - Flush mount: 3 mm (1/8 in.) and 9.5 mm (3/8 in.) drill bits
- #2 Phillips screwdriver
- Jigsaw or rotary tool
- File and sandpaper
- Marine sealant (optional)

Mounting Considerations

The device can be mounted using the included bracket, or it can be mounted flush with the dashboard using a flush-mount kit (may be sold separately).

Before permanently installing any part of your device, you should plan the installation by determining the location of the various components.

- The mounting location must provide a clear view of the screen and access to the keys on the device.
- The mounting location must be sturdy enough to support the device and the mount.
- The cables must be long enough to connect the components to each other and to power.
- The cables can be routed under the bail mount or behind the device.
- To avoid interference with a magnetic compass, the device should not be installed closer to a compass than the compass-safe distance value listed in the product specifications.



Installing the Swivel Base

Fastening the Swivel Mount without the Cables Running through the Mount

You should complete this procedure only if you are not running the power and transducer cables under the mounting surface and through the swivel-mount base.

- 1 Place the base ① on the mounting surface, and fasten it using the appropriate screws or bolts ②.

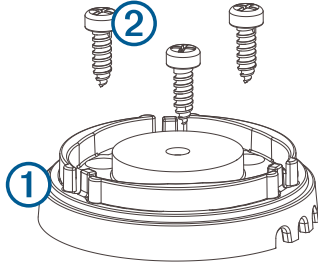

- 2 Place the swivel mount on the base, and replace the 10 mm M6×1 Phillips screw.
- 3 Seal the cable pass-through holes with marine sealant.

Preparing to Run Cables under the Mounting Surface

NOTICE

Use pan-head screws or bolts when securing the swivel-mount base. Screws or bolts with countersunk heads damage the base.

Before you can prepare the swivel-mount base, you must choose the location to install the mount and decide whether to attach the mount using screws or bolts.

- 1 Remove the 10 mm M6×1 Phillips screw ① and separate the swivel mount ② from the base ③.

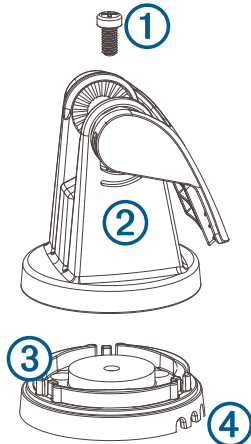

- 2 Orient the swivel base so the pass-through holes ④ face the desired direction.
- 3 Using the swivel base as a template, mark the pilot hole locations ⑤.
- 4 Mark the cable routing hole ⑥.

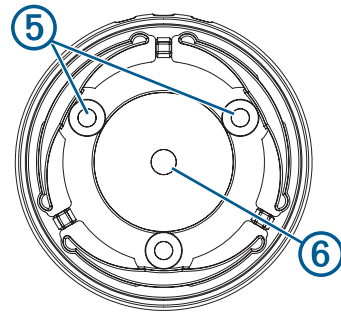

- 5 Using the appropriate drill bit for the hardware, drill the three pilot holes.
- 6 Using a 16 mm ($\frac{5}{8}$ in.) drill bit, drill the cable-routing hole.

Fastening the Swivel Mount with the Cables Running through the Mount

You should complete this procedure only when running the power and transducer cables under the mounting surface and through the swivel-mount base.

- 1 Feed the cables through the 16 mm ($\frac{5}{8}$ in.) center hole you drilled when preparing to run cables beneath the mounting surface.
- 2 Place the base on the mounting surface.
- 3 Route the cables through the cable pass-through holes.
- 4 Loosely fasten the base using the appropriate screws or bolts.
- 5 Place the swivel mount on the base, but do not fasten it.
- 6 Place the cradle or device into the swivel mount (*Installing the Device in the Cradle, page 4*).
- 7 Pull out enough slack from the power and transducer cables so the mount can fully swivel to the desired positions when the cables are connected.
- 8 Remove the cradle and the swivel mount from the base.
- 9 Apply marine sealant to the 16 mm ($\frac{5}{8}$ in.) center hole and to the cable pass-through holes.
- 10 Securely fasten the base with the appropriate screws or bolts.
- 11 Place the swivel mount on the base, and fasten it using the included 10 mm M6×1 Phillips screw.

Installing the Cradle in the Mount

- 1 Pull up the locking arm ①.

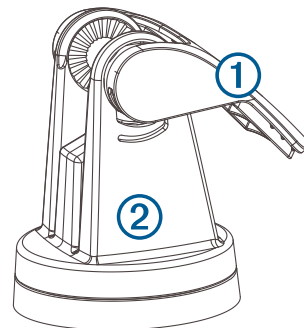

- 2 Place the cradle into the swivel mount ②.
- 3 Tilt the mount to the desired viewing angle.
- 4 Press down the locking arm.

Installing the Cables and Connectors

Wiring to Power

- 1 Route the power cable from the mount to the boat battery or fuse block.

- 2 If necessary, extend the wires using 0.82 mm² (18 AWG) or larger wire.
- 3 Connect the red wire to the positive terminal on the battery or fuse block, and connect the black wire to the negative terminal.

Wiring Harness

- The wiring harness is used for NMEA® 0183 devices, and to share route and waypoint information.
- The wiring harness connects the device to power and NMEA 0183 devices.
- The device has one internal NMEA 0183 port that is used to connect to NMEA 0183 compliant devices.
- If it is necessary to extend the power and ground wires, you must use 0.82 mm² (18 AWG) or larger wire.
- If it is necessary to extend the NMEA 0183 or alarm wires, you must use .33 mm² (22 AWG) wire.

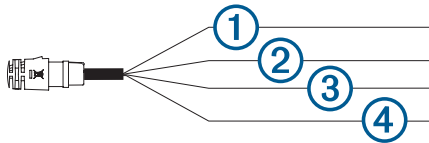

Item	Wire Function	Wire Color
①	NMEA 0183 internal port Rx (in)	Brown
②	NMEA 0183 internal port Tx (out)	Blue
③	Ground (power and NMEA 0183)	Black
④	Power	Red

NMEA 0183 Connection Considerations

- The installation instructions provided with your NMEA 0183 compatible device should contain the information you need to identify the transmitting (Tx) and receiving (Rx) A (+) and B (-) wires. Each port may have one or two transmitting wires, or one or two receiving wires.
- When connecting NMEA 0183 devices to ports containing two transmitting (Tx) wires or two receiving (Rx) wires each, it is not necessary for the NMEA 0183 device to connect to a common ground.
- When connecting a NMEA 0183 device to ports containing one transmitting (Tx) wire or one receiving (Rx) wire each, the NMEA 0183 device must be connected to a common ground.
- When the device is mounted in a location that prevents the internal antenna from acquiring a satellite signal, you can connect an external GPS 19x antenna through a NMEA 0183 connection. For more information, see the *GPS 19x Installation Instructions*.

NMEA 0183 Connection Diagram

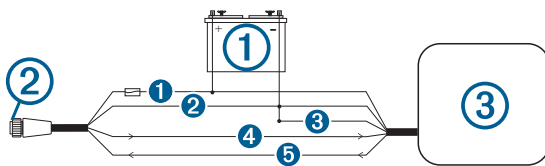

Item	Description
①	12 Vdc power source
②	Wiring harness
③	NMEA 0183 compliant device

Item	Garmin Wire Function	Garmin Wire Color	NMEA 0183 Device Wire Function
①	Power	Red	Power
②	Ground	Black	Data ground
③	Tx/Rx		Tx/Rx/B (-)
④	Tx	Blue	Rx/A (+)
⑤	Rx	Brown	Tx/A (+)

Connecting to a Garmin Device to Share User Data

You can connect the ECHOMAP Plus device to a compatible Garmin device to share user data, such as waypoints. If the devices are mounted near each other, you can connect the blue and brown wires. If the devices are mounted too far apart for the wires to reach, you can connect the devices using a User Data Sharing Cable (010-12234-06).

- 1 Make sure both devices are connected to the same ground.
- 2 Complete an action:
 - If the devices are mounted near each other, connect the blue wire from the first device to the brown wire of the second, and connect the brown wire from the first device to the blue wire of the second.
 - If the devices are not mounted near each other, obtain a User Data Sharing Cable (010-12234-06), and connect the devices following the instructions included with the cable.
- 3 On both devices, select **Navigation Info > Manage Data > User Data Sharing**.

User data is shared between the connected devices. If you select Clear User Data, data is removed from both connected devices.

Connecting the Device to a Transducer

Go to www.garmin.com/transducers or contact your local Garmin dealer to determine the appropriate type of transducer for your needs.

- 1 Follow the instructions provided with your transducer to correctly install it on your boat.
- 2 Route the transducer cable to the back of your device, away from sources of electrical interference.
- 3 Connect the transducer cable to the appropriate port on the cradle.

Connecting the Cables to the Cradle

The connectors on the cables are keyed to fit in only in the correct ports on the cradle. The connected cables are held in place by a locking bracket.

- 1 Slide the cable locking bracket up from the bottom and remove the bracket from the cradle.
- 2 Compare the divots ① on each cable connector to the keying on each port to determine which cable corresponds to each port.

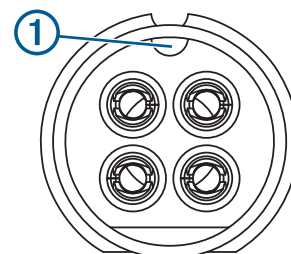

- 3 Fully and firmly insert each cable through a hole in the cradle, and securely connect each cable to a port.

NOTE: If the cables are not inserted far enough into the cradle, the connectors may not connect securely to the ports, and the device may appear to lose power or stop working.

- Place the locking bracket ② over the cables and slide the bracket down to lock the cables in place.

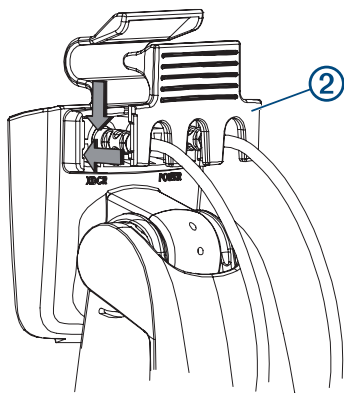

There is an audible click when the locking bracket is installed correctly.

Installing the Device in the Cradle

After the cables are connected to the cradle, you can quickly place the device in the cradle.

- Place the base of the device in the bottom of the cradle.
- Tilt the top of the device toward the cradle until it fastens in place.

There is an audible click when the device is secured in the cradle.

NOTICE

You should make sure the device is firmly secured in the cradle. If the model uses a locking bracket, make sure the bracket is firmly snapped shut. There is an audible click when the device or locking bracket is installed correctly. If the device is not firmly secured, it can lose power. The device can also fall out of the cradle and become damaged if it is not firmly secured.

Removing the Device from the Cradle

- Press the release lever ① on the cradle until the device is released.

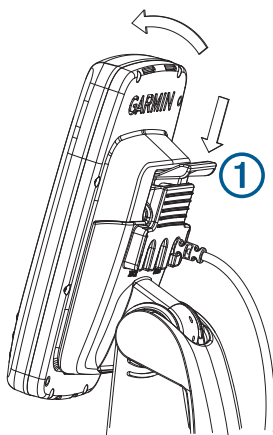

- Tilt the device forward, and lift it out of the cradle.

Specifications

Specification	Measurement
Dimensions on mount (W x H x D)	102.3 x 203.9 x 4.6 mm (4 x 8 x 3 1/8 in.)
Weight	0.7 kg (1.6 lbs.)
Display size (W x H)	53.9 x 95.0 mm (2 1/8 x 3 3/4 in.)
Display type	WQVGA
Display resolution	480 x 272 pixels
Material	Polycarbonate plastic
Water rating ¹	IEC 60529 IPX7
Temperature range	From -15 to 55°C (from 5 to 131°F)
Fuse	3 A, 125 V fast-acting
Input voltage	From 9 to 18 Vdc
Max. power draw ²	5 W
Typical current draw (RMS) ²	0.5 A
Max. current draw (RMS) ²	2 A
Compass-safe distance	25 cm (9.8 in.)
Sonar frequencies ³	Traditional: 50, 77, 83, or 200 kHz CHIRP Garmin ClearVü: 260, 455, or 800 kHz
Transmit power (RMS) ³	500 W
Maximum depth ⁴	701 m (2,300 ft) at 77 kHz
Memory card	1 microSD® card slot; 32 GB max. card size
Max. waypoints	5,000
Max. routes	100
Max. active track points	50,000 points, 50 saved tracks

¹The device withstands incidental exposure to water of up to 1 m for up to 30 min. For more information, go to www.garmin.com/waterrating.

²Dependent upon transducer and chartplotter model.

³Dependent upon transducer.

⁴Maximum depth is dependent upon transducer, water salinity, bottom type, and other water conditions.

NMEA 0183 Information

Transmit

Sentence	Description
GPAPB	APB: Heading or track controller (autopilot) sentence "B"
GPBOD	BOD: Bearing (origin to destination)
GPBWC	BWC: Bearing and distance to waypoint
GPGGA	GGA: Global positioning system fix data
GPGLL	GLL: Geographic position (latitude and longitude)
GPGSA	GSA: GNSS DOP and active satellites
GPGSV	GSV: GNSS satellites in view
GPRMB	RMB: Recommended minimum navigation information
GPRMC	RMC: Recommended minimum specific GNSS data
GPRTE	RTE: Routes
GPVTG	VTG: Course over ground and ground speed
GPWPL	WPL: Waypoint location
GPXTE	XTE: Cross track error
PGRME	E: Estimated error
PGRMM	M: Map datum
PGRMZ	Z: Altitude
SDDBT	DBT: Depth below transducer
SDDPT	DPT: Depth
SDMTW	MTW: Water temperature
SDVHW	VHW: Water speed and heading

Receive

Sentence	Description
DPT	Depth
DBT	Depth below transducer
MTW	Water temperature
VHW	Water speed and heading
WPL	Waypoint location
DSC	Digital selective calling information
DSE	Expanded digital selective calling
HDG	Heading, deviation, and variation
HDM	Heading, magnetic
MWD	Wind direction and speed
MDA	Meteorological composite
MWV	Wind speed and angle
VDM	AIS VHF data-link message

You can purchase complete information about National Marine Electronics Association (NMEA) format and sentences from: NMEA, Seven Riggs Avenue, Severna Park, MD 21146 USA (www.nmea.org)

© 2017 Garmin Ltd. or its subsidiaries

Garmin® and the Garmin logo are trademarks of Garmin Ltd. or its subsidiaries, registered in the USA and other countries. ECHOMAP™, Garmin ClearVü™, and Garmin Quickdraw™ are trademarks of Garmin Ltd. or its subsidiaries. These trademarks may not be used without the express permission of Garmin.

NMEA® is a registered trademark of the National Marine Electronics Association. NMEA® is a registered trademark of the National Marine Electronics Association. The microSD® logo is a trademark of SD-3C, LLC.

