

Fishfinder 340C

full-featured color sonar



© 2007 Garmin Ltd. or its subsidiaries

Garmin International, Inc.
1200 East 151st Street,
Olathe, Kansas 66062, USA
Tel. (913) 397.8200 or (800) 800.1020
Fax (913) 397.8282

Garmin (Europe) Ltd.
Liberty House
Hounslow Business Park,
Southampton, Hampshire, SO40 9RB UK
Tel. +44 (0) 870.8501241 (outside the UK)
0808 2380000 (within the UK)
Fax +44 (0) 870.8501251

Garmin Corporation
No. 68, Jangshu 2nd Road,
Shijr, Taipei County, Taiwan
Tel. 886/2.2642.9199
Fax 886/2.2642.9099

All rights reserved. Except as expressly provided herein, no part of this manual may be reproduced, copied, transmitted, disseminated, downloaded or stored in any storage medium, for any purpose without the express prior written consent of Garmin. Garmin hereby grants permission to download a single copy of this manual onto a hard drive or other electronic storage medium to be viewed and to print one copy of this manual or of any revision hereto, provided that such electronic or printed copy of this manual must contain the complete text of this copyright notice and provided further that any unauthorized commercial distribution of this manual or any revision hereto is strictly prohibited.



Information in this document is subject to change without notice. Garmin reserves the right to change or improve its products and to make changes in the content without obligation to notify any person or organization of such changes or improvements. Visit the Garmin Web site (www.garmin.com) for current updates and supplemental information concerning the use and operation of this and other Garmin products.

Garmin® is a trademark of Garmin Ltd. or its subsidiaries, registered in the USA and other countries. CANet™, DynaColor™, and Ultrascroll™, AutoLocate®, TracBack®, BlueChart®, and MapSource® are trademarks of Garmin Ltd. or its subsidiaries. These trademarks may not be used without the express permission of Garmin.

INTRODUCTION

Thank you for choosing the Garmin® Fishfinder 340C. The Fishfinder 340C is a full-featured, color sonar that offers a choice of display styles, a dual beam or dual frequency option, and many more features, including the following:

- Ultrascroll™, which gives you a much faster update rate on your Sonar Pages.
- Auto Gain, which allows you to see more fish and structures.
- CANet™ capability, which allows you to connect your unit to CANet-capable Garmin chartplotters, so you can read the Sonar Pages on chartplotters located elsewhere in the boat.
- Round flasher, which gives you an option for how to view the sonar.
- Whiteline, which helps you to interpret bottom hardness.
- 2x and 4x automatic and manual zoom.
- Adjustable keel offset.
- Alarms for fish size, shallow water, deep water, and low battery.
- NMEA sonar data output and navigation data input.

About This Manual

To get the most out of your Fishfinder 340C, read this manual and learn the operating procedures. This manual includes the following:

- **Introduction**—contains the Table of Contents, product registration, contact, and cleaning information.
- **Getting Started**—provides general information that can help you before you install and use your Fishfinder 340C.
- **Installing the Fishfinder 340C**—covers the installation and testing for the Fishfinder 340C.
- **Using the Fishfinder 340C**—provides details about the features and operations of the Fishfinder 340C.
- **Appendix**—contains information, such as specifications, optional accessories, and messages that might appear. You can also find warranty information in the Appendix.
- **Index**—helps you quickly find information in this manual.

This manual uses the term **Warning** to indicate a potentially hazardous situation, which, if not avoided, could result in death or serious injury.

This manual uses the term **Caution** to indicate a potentially hazardous situation, which, if not avoided, may result in minor injury or property damage. It may also be used without the symbol to alert you to avoid unsafe practices.

TABLE OF CONTENTS

Introduction	i	Using the Fishfinder 340C	21
About This Manual	i	Learning the Basic Functions	21
Product Registration	iii	Using the Fishfinder 340C Keypad	22
Contact Garmin	iii	Understanding the Main Pages	23
Caring for the Fishfinder	iii	Using the Main Menu	26
Warning	iv	Using the Adjustment Menu	34
Getting Started	1	Configuring Advanced Data Fields	37
Packing List	1	Pausing a Sonar or Flasher Page	39
Optional Accessories	1	Marking a Waypoint	40
Understanding the Fishfinder and Sonar	2	Appendix	42
Installing the Fishfinder 340C	5	Specifications	42
Selecting a Location for the Fishfinder	5	Optional Accessories	42
Mounting the Fishfinder	6	Messages and Alarms	43
Mounting the Transducer	9	Limited Warranty	44
Installing the Wiring Harness	15	Software License Agreement	45
Testing the Installation	20	Index	46

Product Registration

Help us better support you by completing our online registration today! Have the serial number of your Fishfinder handy, and connect to our Web site (<http://www.garmin.com>). Look for the **Product Registration** link on our Home page.

Use this area to record the serial number (8-digit number located on the back of the box). Be sure to keep your original sales receipt in a safe place, or attach a photocopy inside the manual.

Serial Number: ____ _

Contact Garmin

If you encounter any difficulty while using your Fishfinder, or if you have any questions, in the U.S.A. contact Garmin Product Support by phone: 913/397.8200 or 800/800.1020, Monday–Friday, 8 AM–5 PM Central Time; or go to www.garmin.com/support/ and click on **Product Support**. In Europe, contact Garmin (Europe) Ltd. at 44/0870.8501241.

Caring for the Fishfinder

The Fishfinder case is constructed of high-quality materials and does not require user maintenance except cleaning.

Cleaning the Case

Clean the Fishfinder's outer casing (except for the screen) using a cloth dampened with a mild detergent solution. Wipe it dry. Avoid chemical cleaners and solvents that can damage plastic components.

Cleaning the Screen

Apply eyeglass lens cleaner to a clean, lint-free cloth, and then gently wipe the screen with the moistened cloth.



CAUTION: The Fishfinder 340C lens is coated with a special anti-reflective coating which is very sensitive to skin oils, waxes, and abrasive cleaners. **CLEANERS CONTAINING AMMONIA HARM THE ANTI-REFLECTIVE COATING.**

Storage

Do not store the Fishfinder where prolonged exposure to temperature extremes might occur (such as in the trunk of a car), because permanent damage can result.

Water Immersion

The Fishfinder is waterproof to IEC Standard 60529 IPX7. It can withstand immersion in 1 meter of water for 30 minutes. Prolonged submersion can cause damage to the Fishfinder. After submersion, wipe and air dry the Fishfinder before reusing.

 **Warning**

Failure to avoid the following potentially hazardous situations could result in an accident or collision resulting in death or serious injury:

When navigating, carefully compare information displayed on the Fishfinder 340C to all available navigation sources, including information from visual sightings, and maps. For safety, always resolve any discrepancies or questions before continuing navigation.

WARNING: This product, its packaging, and its components contain chemicals known to the State of California to cause cancer, birth defects, or reproductive harm. This Notice is being provided in accordance with California's Proposition 65. If you have any questions or would like additional information, please refer to our Web site at <http://www.garmin.com/prop65>.

 - LAMPS INSIDE THIS PRODUCT CONTAIN MERCURY AND MUST BE RECYCLED OR DISPOSED OF ACCORDING TO LOCAL, STATE, OR FEDERAL LAWS.

For more information go to:

www.garmin.com/aboutGarmin/environment/disposal.jsp.

The California Electronic Waste Recycling Act of 2003 requires the recycling of certain electronics. For more information on the applicability to this product, see www.e-recycle.org.

GETTING STARTED

Before installing and using your Fishfinder 340C, check to see that your package includes the following items. The package number is on the outside of the box. If any parts are missing, contact your Garmin dealer immediately.

Packing List

Standard Package (010-00505-00)

- Fishfinder 340C unit
- Tilt/swivel mount
- 6-foot data/power cable
- Owner's manual
- Quick reference guide
- Flush mount template
- Protective cover
- Flush mount hardware kit

Optional Package (010-00505-01)

- Standard package
- Dual beam (14°/45°) plastic trolling motor/transom mount transducer with depth and temperature and an attached 30-foot cable

Optional Package (010-00505-02)

- Standard package
- Dual frequency (200/50kHz) plastic transom mount transducer with depth and temperature and an attached 30-foot cable

Optional Package (010-00505-03 with Worldwide Language Support)

- Standard package
- Dual frequency (200/50kHz) plastic transom mount transducer with depth and temperature and an attached 30-foot cable

Optional Accessories

The following optional accessories are available at www.garmin.com:

- Speed sensors
- Quick-release flush mount kit
- CANet™ connection kit
- Optional transducers and transducer accessories

Understanding the Fishfinder and Sonar

The Fishfinder 340C is a fully automatic, color sonar unit that allows you to go out on the water and find fish without having to configure a lot of settings. However, you can customize each setting as you prefer.

If you have used a Fishfinder before, you might already know how to interpret the sonar information on the screen, so you can skip this section. If you have not used a Fishfinder before, you might want to learn a bit about sonar: what it is, how it works, and what you might see on the Fishfinder 340C screen. This manual provides a general understanding of those things that you need to know about sonar that can help you interpret the screen and find the fish.

Understanding Sonar

During installation, you connect your Fishfinder 340C to a transducer. The transducer uses sound to determine information about what is in the water beneath your boat. Then the transducer sends the information to your Fishfinder to be shown on the screen for you to view and interpret.

The transducer sends sound waves down into the water in a cone shape, similar to a flashlight beam (covering a smaller circular area at the top and angling out to a larger circular area at the bottom). These sound waves reflect off of any object that they hit, and then the waves travel back up to the transducer. These objects could be fish, branches, the bottom, or any other object that has density that is different from the water. The transducer receives the sound wave information, and then sends the information to the Fishfinder. The Fishfinder shows the information on the screen for you to see and interpret. The type of transducer and settings that you choose determine how the information appears on the screen.

Using Dual Frequency

Dual frequency works best for deep water (for example, off-shore) applications. The 200 kHz frequency allows you access to great detail about what is underneath your boat. The 50 kHz frequency provides less detailed information, but penetrates to greater depths with the same power. You can choose either or both frequencies to get the information that you want. If you choose dual frequency, the transducer alternates between the 50 kHz and 200 kHz signals. This capability allows you to see the best picture available at any depth.

Using Dual Beam

Dual beam works best for shallow water (for example, inland) applications. A dual beam transducer can transmit a narrow or a wide beam. The water area covered by the transmitted sound waves is determined by the beam width of the transducer and the water depth. The narrow beam provides crisp detail of what is under your boat, and is very helpful if you are fishing in deeper water where the beam covers more area (for example, at a depth of 30 feet, the narrow beam covers the area of about a 7-foot circle).

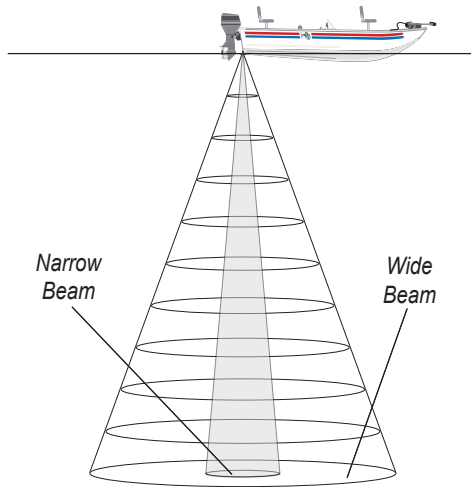

The wide beam is more helpful in shallow water, because it gives you a much wider view of objects in the water, including areas beyond the sides of your boat. At a depth of 30 feet, the wide beam covers the area of approximately a 20-foot circle.

Understanding the Fishfinder Screen

Experimentation and experience are the keys to successfully interpreting your Fishfinder screen. We recommend that you take your Fishfinder out on familiar water, and spend time learning to interpret what you see on the Fishfinder 340C screen.

Think of the Fishfinder screen as if you took a picture from the side of an aquarium in your home. You can see how deep a fish is in the water (how close it is to the top or bottom), but you cannot tell where the fish is located horizontally in the water (whether it is near the front or the back of the aquarium). Remember this when you are trying to locate exactly where something is in the water.

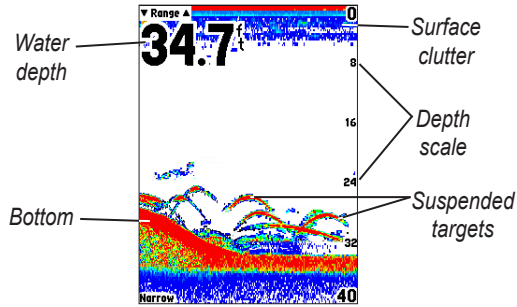

The strongest sonar returns appear on your screen as the most intense solid color (depending on your selected color scheme; red is the default). The weakest returns appear as the less intense, less solid colors (blue is the default).

The bottom of the water is always going to be the strongest signal, and therefore the most intense color. The bottom is the continuous, intensely-colored line running across the bottom of the screen. The Fishfinder 340C includes the latest technology in interpreting bottom signals; it can see through fish, structures, and thermoclines (shown in the weakest colors). Large schools of fish or dense structures close to the bottom can affect water depth return readings.



NOTE: If the Fishfinder is unable to track the bottom for any reason, the digits which indicate depth flash on and off to alert you that the Fishfinder is not tracking the bottom.

Along the top of the screen, you might see a grouping of intense colors. This area is surface clutter, which can be caused by waves or any other sonar interference at the surface of the water. Too much surface clutter can obscure your view of fish. You can turn down the Gain setting to reduce this surface clutter.

Between the bottom and the surface clutter, you see suspended targets in the previous illustration. Here, the targets appear as arches. Actual suspended target returns might not always appear as perfect arches, due to the speed, fish orientation, or other conditions. You can turn on the Fish Symbols setting if you want to see suspended targets indicated by a fish shape.

The strength of the sonar return can also help you interpret the hardness of the bottom of the water. The thicker the bottom line, the harder the bottom.

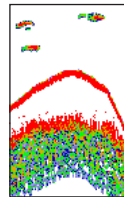

Hard Structure

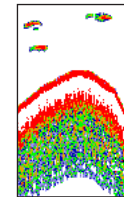

Soft Structure

INSTALLING THE FISHFINDER 340C

To ensure the successful operation of your Fishfinder 340C, you must properly install the Fishfinder and all of its related parts.

To install and use your Fishfinder, you must do the following:

1. Select a proper location for the Fishfinder.
2. Mount the Fishfinder.
3. Install your transducer.
4. Connect to your power source.
5. Test the installation.

Each of these steps is described in detail in the following sections.

Selecting a Location for the Fishfinder

Consider the following when you select an installation location:

- Provides optimal viewing as you operate your vessel.
- Allows easy access to the unit's keypad.
- Is strong enough to support the weight of the Fishfinder and protect it from excessive vibration or shock.
- Allows room for the routing and connection of the power/ data and transducer cables. There should be at least a 3-inch (8 cm) clearance behind the case.

DO NOT mount the unit in an area that is exposed to extreme temperature conditions.



NOTE: The temperature range for the Fishfinder 340C is 5°F to 131°F (-15°C to 55°C). Extended exposure to temperatures exceeding this range (in storage or operating conditions) may cause failure of the LCD screen. This type of failure and related consequences are NOT covered by the manufacturer's limited warranty.

To get the best possible performance from your Fishfinder 340C:

- Read the instructions first, and then follow the instructions to install the unit.
- Gather the appropriate fasteners and tools.
- Verify that all cables can reach the unit mounting location and the transducer.
- Wear safety goggles and a dust mask when drilling, cutting, or sanding.

If you experience difficulty installing the unit, contact Garmin Product Support or contact a professional installer.

Mounting the Fishfinder

There are two possible installation methods for your Fishfinder:

- You can mount the Fishfinder onto a bracket that attaches to the console or overhead.
- You can flush mount the Fishfinder into a flat panel.

Surface Mounting the Fishfinder

The Fishfinder 340C's compact, waterproof case is suitable for mounting in exposed locations or at the nav station. The Fishfinder comes with a tilt/swivel mounting bracket that can be used for console or overhead mounting.

Mounting the Bracket Assembly

Tools (not included)—drill, screwdriver (Phillips or standard), and one of the following:

- Three #8 (4 mm) pan-head machine bolts with matching nuts and washers and a 5/32" (5 mm) drill bit.
- Three #8 pan-head self-tapping screws and a 1/16" drill bit for drilling starter holes.

Use a pan-head machine bolt or self-tapping screw to secure the swivel base. If you use a screw with a countersunk head, you risk damaging the mounting bracket.

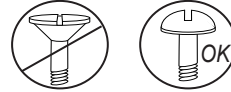

To mount the bracket assembly:

1. Using the swivel base as a template, mark the location of the three holes that secure the bracket to the mounting surface.
2. Drill the mounting holes.
 - If you secure the base with machine bolts, drill three 5/32" (5 mm) holes at the locations you marked.
 - If you secure the base with self-tapping screws, drill starter holes at the locations you marked. Do not make the starter holes deeper than half the screw length.



3. Secure the swivel base with three bolts or screws. **DO NOT OVERTIGHTEN.**
4. Place the swivel mount bracket over the swivel base and secure it with the short knob.

Installing the Unit on the Mounting Bracket

To install the Fishfinder on the mounting bracket:

1. Align the slot on the back of the Fishfinder with the long mounting knob, and slide the Fishfinder into place. If necessary, adjust the long knob to spread the bracket arms apart. (Turn counter-clockwise to widen the bracket arms and clockwise to tighten.)
2. Adjust the Fishfinder angle, and tighten the long mounting knob until snug.



3. Rotate the swivel mount bracket by twisting it left or right. The bracket clicks as you turn it. Select a good viewing angle, and then tighten all knobs.
4. Connect the power/data and transducer cables to the back of the Fishfinder, making sure the locking rings are fully tightened on both connectors.

Flush Mounting the Fishfinder

You can flush mount the Fishfinder 340C into a flat panel.

- Select an appropriately sized location for the unit.
- Use the Flush Mount Template provided in the box to determine a location.
- Check that all cables reach the unit mounting location.
- Always wear safety goggles and a dust mask when drilling, cutting, or sanding.

Included mounting hardware—(4) 3 mm studs, (4) flat washers, and (8) 3 mm hex nuts.

Tools (not included)—center punch, drill, 1/8" (3 mm) drill bit, 3/8" (6 mm) drill bit, jig saw, 1/16" (2 mm) Allen wrench, and 9/32" (7 mm) wrench.

To flush mount the Fishfinder 340C:

1. Trim the Flush Mount Template, and tape it to the chosen location.
2. Using a center punch, indent the center of each mounting hole location.
3. Using an 1/8" (3 mm) drill bit, drill the four mounting holes.
4. Using a 3/8" (6 mm) drill bit, drill a hole for a location to begin cutting the mounting surface.
5. Using the jig saw, cut the mounting surface along the inside of the dashed line indicated on the template. Be very careful when cutting this hole, there is only a small amount of clearance between the Fishfinder and the mounting holes. You can cut slightly inside the indicated line and then sand or file the panel, as needed, to obtain the best fit.
6. Install the four mounting studs into the Fishfinder by screwing the shorter section into the back of the Fishfinder. Use a 1/16" (2 mm) Allen wrench to tighten the mounting studs until the stop contacts the case. Be careful not to overtighten, because this can damage the mounting stud! The studs have a reusable thread-locking patch pre-applied from the factory.
7. Place the Fishfinder into the cut out in the mounting surface.

8. Place washers over the mounting studs, and then thread on one hex nut per mounting stud. Tighten all four until the Fishfinder is snug against the mounting surface. Install and tighten the second hex nut on all four mounting studs to lock the first one into place.

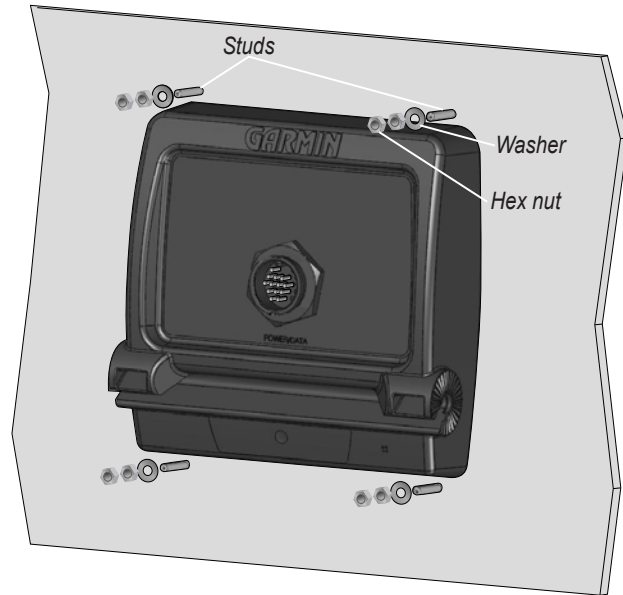

Mounting Surface (Back View)

Mounting the Transducer

Proper transducer installation is key to getting the best performance from your new Fishfinder. If the transducer lead is too short, extension cables are available from your Garmin dealer. Coil and secure any excess cable.



CAUTION: DO NOT cut the transducer lead or any part of the transducer cable, because cutting the transducer cable voids your warranty. The cable cannot be spliced and connected to any existing (Garmin or non-Garmin) transducer cables.

The following pages contain tips and basic installation instructions for some popular transducers. Detailed installation instructions are provided in the transducer kits. Some transducers might have to be installed by a professional marine installer.

Assembling the Transducer

To assemble the transducer:

1. Insert the rubber washer and plastic spacer into the transducer at the same time. DO NOT lubricate the rubber washer.
2. Route the cable toward the back of the transducer. Slide the transducer into the transducer mount.
3. Place a 5 mm flat washer on the 10-32 x 1.75" screw, and insert the screw through the transducer mount, spacer, and rubber washer.
4. Place the remaining 5 mm flat washer on the exposed end. Install the 10-32 lock nut finger tight. You can tighten the transducer further after installation on the boat.

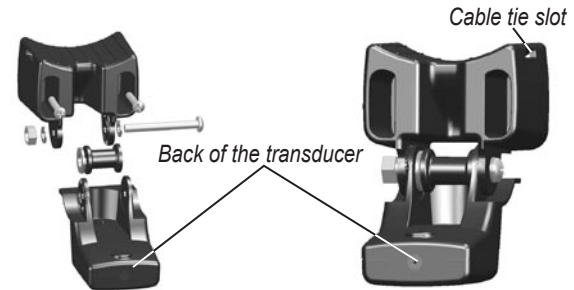

Mounting the Transducer on a Trolling Motor (Dual Beam Only)

To mount the transducer on a trolling motor:

1. Slide the large cable tie through the slot on the transducer mount (see the illustration on [page 9](#)) with the ridges of the band facing up until equal lengths extend on both sides of the mount. (**NOTE:** For cold water, or heavy timber or debris areas, a metal 4-5" worm gear clamp is recommended.)
2. Position the mount gasket on the curved top of the transducer mount.

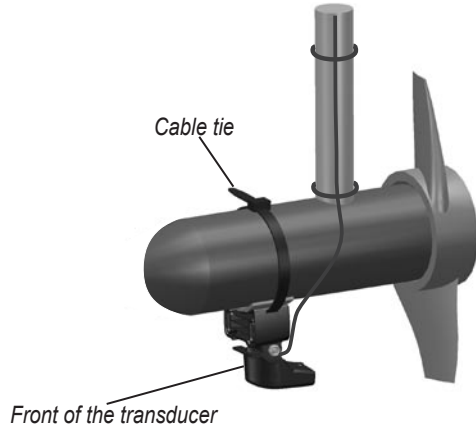

3. Place the transducer assembly against the motor body of the trolling motor, with the front of the transducer pointed away from the trolling motor propeller.
4. Wrap the two ends of the cable tie around the motor body. Place the pointed end of the cable tie through the fastener hole on the opposite end and pull it through until it is snug but not tight. (The cable tie clicks when you pull it.)
5. Position the transducer so that it is parallel with the bottom when in use, and make sure the gasket is aligned properly. Pull the cable tie end until tight. Trim off the excess if necessary. Tighten the 10-32 locking nut until it touches the mounting bracket, and then tighten 1/4 turn more. (Do not overtighten.)
6. Route the 30-foot (9 m) transducer cable using the supplied cable ties to secure the cable to the motor shaft. You can fill the forward-facing portion (except the cable tie pocket) of the transducer mount with sealant to avoid accumulating debris.

Mounting the Transducer on a Transom

When selecting a transom mount location, consider the following for optimal performance:

- For your sonar to operate properly, the transducer must be located in calm water. **DO NOT** mount the transducer behind strakes, rivet lines, struts, fittings, water intake, discharge ports, eroding paint, or anything that creates turbulence.
- Mount the transducer as close to the center of the boat as possible.
- **DO NOT** cut the transducer lead. (This voids your warranty.)
- **DO NOT** mount the transducer in locations where it might be jarred when launching, hauling, trailering, or storing.
- **DO NOT** mount the transducer in the path of the prop on single-drive boats. The transducer can cause cavitation that can degrade the boat's performance and damage the prop. On twin-drive boats, mount the transducer between the drives, if possible.

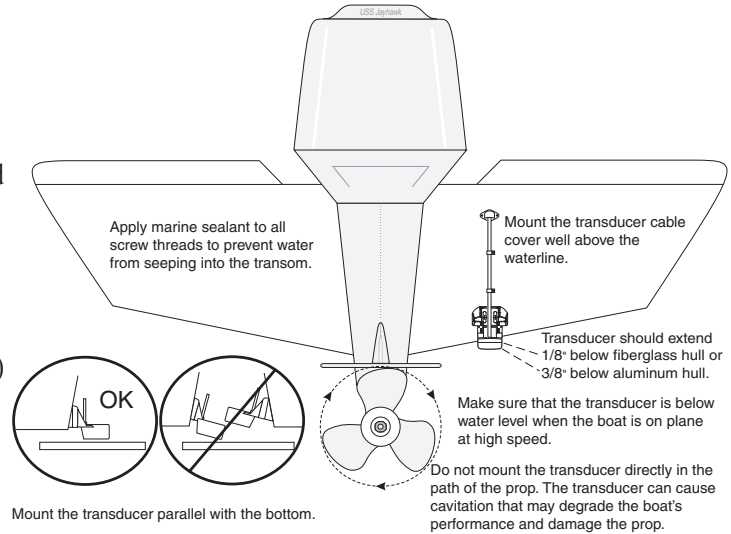

NOTE: **DO NOT** mount the transducer behind strakes, struts, fittings, water intake or discharge ports, or anything that creates air bubbles or causes the water to become turbulent. The transducer must be in clean (non-turbulent) water for optimal performance.

Tool List (not included)—drill, 3/8" wrench or socket, 5/32" and 1/8" drill bits, masking tape, #2 Phillips screwdriver, and marine sealant.

To mount the transducer on a transom:

1. Position the transducer mount at the selected transom location. Make sure the transducer is parallel with the water line. Mark the center locations of each hole on the transducer mount.
2. Using a 5/32" bit, drill the pilot holes approximately 1" (25 mm) deep at the marked locations. To avoid drilling the holes too deep, wrap a piece of tape around the bit at 1" from the point of the bit.
3. Apply marine sealant to the 5 x 30 mm screws. Attach the transducer assembly to the transom using the 5 x 30 mm screws. Adjust the transducer assembly to extend beyond the bottom of the transom approximately 1/8" (3 mm) on fiberglass hulls or 3/8" (10 mm) on aluminum hulls. Adjust the transducer assembly to be aligned parallel with the water.
4. Tighten the 10-32 locking nut until it touches the mounting bracket, and then tighten 1/4 turn more. (Do not overtighten.)
5. Place the first cable clamp on the transducer cable approximately one third of the distance between the transducer and the top of the transom.

Mark the location. Using a 1/8" bit, drill a pilot hole approximately 3/8" (10 mm) deep.

6. Attach the cable clamp using a 4 x 12 mm screw. Coat the screw with marine sealant before installation. Repeat steps 5 and 6 using the other cable clamp.
7. Route the transducer cable, as needed, to the Fishfinder. **DO NOT CUT THE CABLE.** Avoid routing the cable with electrical wires or other sources of electrical interference.

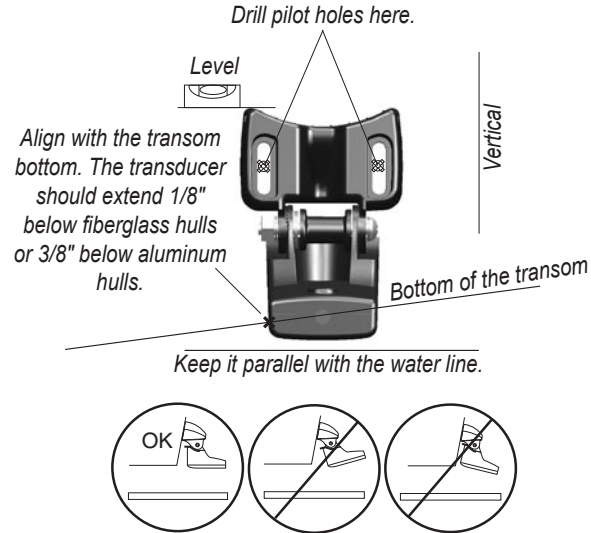

Shoot-Thru-Hull Installation

To avoid drilling a hole to mount a thru-hull transducer, a transducer can be secured with epoxy inside a boat (shoot-thru-hull installation). This type of installation can provide better noise reduction and allow you to use a higher Gain setting. For a transducer to be mounted inside the hull (shoot-thru, not thru-hull), the boat must be fiberglass, with no core. Contact your boat manufacturer if you are unsure. Professional installation might be necessary. Be sure to always wear a dust mask and safety goggles.

Some transducers are specifically designed to be mounted inside a fiberglass hull. The standard plastic transom mount transducer can also be mounted using this method. If using a temperature sensing transducer, the temperature shown reflects the hull temperature.

Selecting a Location for a Shoot-Thru-Hull Installation

When installing a transducer, the installation location must be the following:

- Solid fiberglass, without any air bubbles, laminates, fillers, or dead air space.
- In an area of clean (non-turbulent) water at all speeds.
- The location must not be over any strakes or behind any obstruction on the hull that would create turbulence at speed.



NOTE: Many modern hulls have a dedicated pocket for shoot-thru-hull transducer installation. If you are unsure if your hull is equipped with a pre-located pocket, contact your hull manufacturer.

To test the location:

1. Fabricate a test device from a section of PVC pipe or a can, as shown in the following illustration.
2. Temporarily seal the test device to the hull with caulking or RTV sealer, and fill with water or light mineral oil.
3. Place the transducer in the water, pointed directly at the bottom and weight it down. Set the unit for optimum performance. If the sonar performance is significantly degraded, another location must be tested.

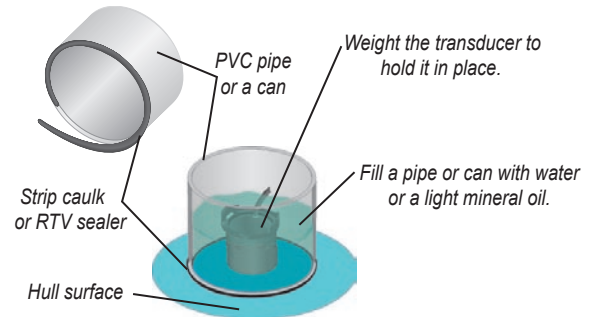

Testing the Location

To permanently install the transducer:

1. Lightly sand the surface of the hull and face of the transducer with 400 grit wet or dry sandpaper.
2. Build a dam using strip caulk about 1/4" (6 mm) tall. Pour about 1/8" (3 mm) of two-part, slow-cure epoxy into the dam.
3. Place the transducer in the epoxy, turning the transducer to work out any air bubbles.
4. Weight the transducer in place, and allow it to cure for 24 hours.

Installing the Wiring Harness

The Fishfinder comes with a wiring harness that connects the Fishfinder to power and the transducer with one easy-to-remove connection and provides interface capabilities for connecting external devices. The color code in the diagram (see [page 17](#)) indicates the appropriate harness connections. The replacement fuse is a AGC/3AG - 3 Amp fuse. If it is necessary to extend the power wires, use 22 AWG wire. DO NOT cut the transducer cable, because this voids your warranty. If your boat has an electrical system, you might be able to wire the Fishfinder directly to an unused holder on your current fuse block. If you are using the boat's fuse block, remove the in-line fuse holder supplied with the Fishfinder. You can also wire the Fishfinder directly to the battery.



CAUTION: The Fishfinder input voltage is 33 volts DC. Do not exceed this voltage, because this can damage the Fishfinder and void the warranty.



NOTE: During a typical installation, use only the Red and Black wires. The other wires do not have to be connected for normal operation of the Fishfinder unit. For information on connecting to a NMEA or CANet compatible device, see [pages 17-19](#).

To install the wiring harness:

1. Use a test light or voltmeter to determine the polarity of the voltage source.
2. Connect the Red (+ or positive) wire to the positive voltage terminal. (If you use the boat's fuse block, route the positive connection through the fuse, as shown on the diagram.)
3. Connect the Black (- or ground) wire to the negative voltage terminal.
4. Install or check the 3-Amp fuse (on the boat's fuse block or in the in-line holder).
5. Align the notches on the cable plug and on the back of the Fishfinder. Insert the cable into the connector, and turn the lock ring counter-clockwise until it stops.

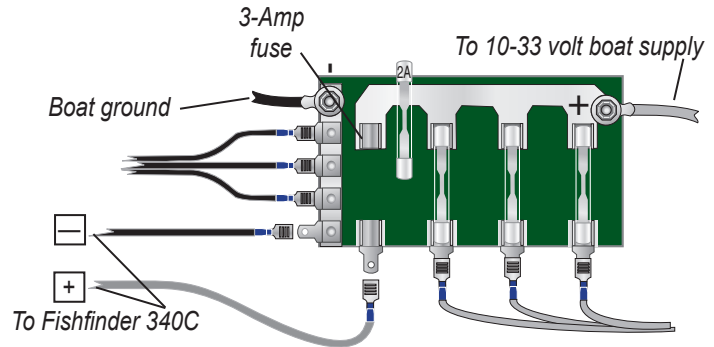

The Fishfinder 340C can be connected to another piece of NMEA compatible electronic equipment, such as a Garmin GPS (Global Positioning System) device. If equipped with a capable transducer, the Fishfinder 340C can send depth, temperature, and speed information. It can also mark a location that can be viewed and possibly saved on another device (see [page 41](#)). The Fishfinder 340C can also accept GPS navigational data, such as position, time, course, or distance. Refer to the wiring diagrams for interfacing the Fishfinder 340C with other devices (see [pages 17 and 19](#)).

To install the wiring harness to a GPS or other NMEA device:

1. Follow the voltage source installation steps (see [page 15](#)). For Garmin units, the ground (Black) wires serve as data ground and must be attached together or on the same terminal. Refer to the wiring diagram of your GPS unit for wire identification.
2. Connect the Blue (Data OUT) wire from the Fishfinder to the Data IN wire on the GPS/NMEA harness.
3. Connect the Brown (Data IN) wire from the Fishfinder to the Data OUT wire on the GPS/NMEA harness.
4. Set the Fishfinder 340C NMEA Input/Output to **On** ([page 32](#)). For Garmin GPS units, set the communications interface to **NMEA/NMEA**, **NMEA In/NMEA Out**, or **NMEA**.

Interfacing with NMEA

The Fishfinder 340C allows for NMEA 0183, Version 3.01 input/output with a compatible GPS or navigation device. You must set **NMEA Input/Output** to **On** to send or receive data ([page 32](#)).

The following sentences are for NMEA 0183, Version 3.01:

Input—GPBOD, GPBWC (only used if RMB is not present), GPGGA, GPGLL (only used if GGA not present), GPRMB, GPRMC, GPXTE (only used if RMB is not present).

Output—SDDBT, SDDPT, SDMTW, SDVHW, SDWPL* (only if a waypoint is marked in Pointer mode).

*Garmin GPS units accept an SDWPL (WPL) NMEA sentence and create a waypoint (saved location) at that position ([page 40](#)). For compatibility with other brands of GPS or NMEA capable navigation devices, check with those manufacturers to see if their units accept and store NMEA 0183 SDWPL sentences and waypoints. The Fishfinder 340C does not store the actual waypoint. Only the receiving device, if capable, stores the waypoint.

You can purchase complete information about National Marine Electronics Association (NMEA) format and sentences from NMEA at:

NMEA
Seven Riggs Avenue
Severna Park, MD 21146 USA
www.nmea.org

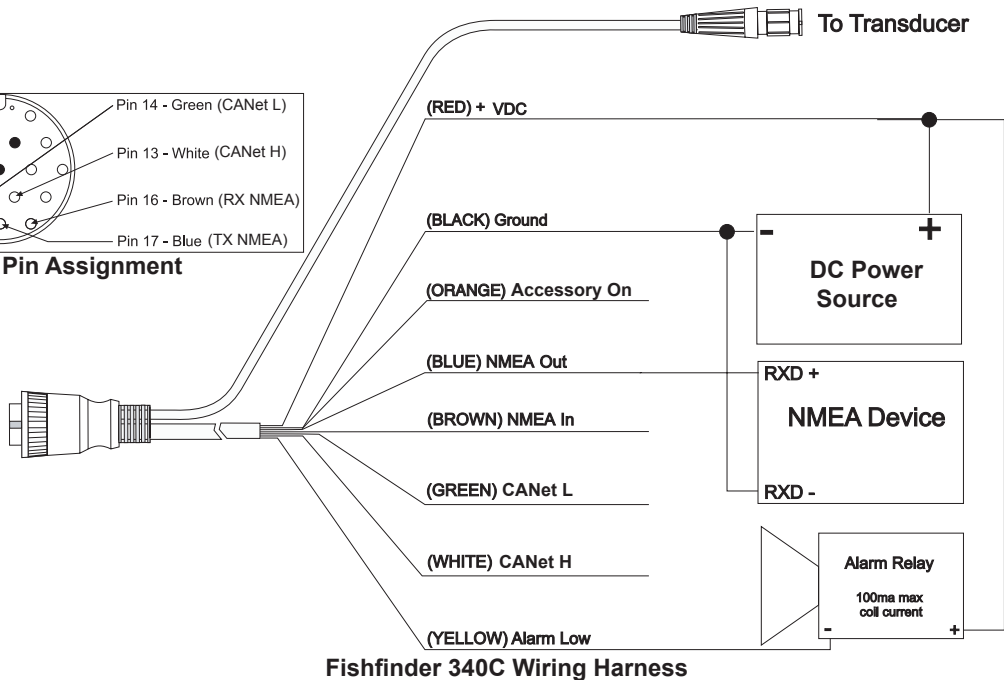
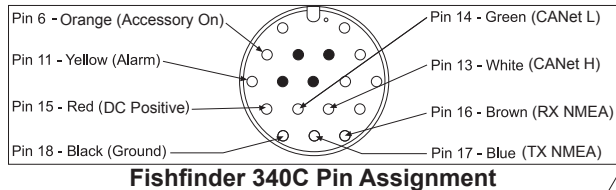

Installing the Fishfinder 340C to a Garmin CANet

The Fishfinder 340C is a CANet compatible sonar device. Using the CANet - if applicable - optimizes the performance of CANet-compatible units, allowing sonar information from the Fishfinder 340C to be shared with up to two CANet compatible Garmin GPS units. A standard NMEA connection only allows depth, temperature, and speed information to be sent to a single GPS device, where a CANet connection provides full sonar readings, including Ultrascroll, so you can view and control the same information on your compatible GPS unit(s) as you can on your Fishfinder 340C.



NOTE: To use the Garmin CANet with your Fishfinder 340C, you need to obtain a CANet Kit. Contact your Garmin dealer, or visit www.garmin.com.

Included Equipment in a CANet Kit:

- 40 ft (12.19 m) CANet Extension Cable
- 2 CANet Terminators
- 7 3-Wire Connectors



NOTE: The CANet Kit contain installation instructions as well. If you need additional help, please contact Garmin Product Support.

To install the 3-Wire Connector:

1. Insert up to wires into the 3-wire connector. Do not strip the wire insulation. See the CANet Terminator Connection diagram on the next page.
2. Use a standard pair of pliers to fully depress the red button into the connector.
3. Wipe the excess water repellent gel from the connection.

CANet Notes:

- Power and ground wires require 18 AWG. You can extend the CANet wiring of the GSD 22 power/data cable up to 80 ft (24.38 m) total length using the CANet Connections Kit.
- The CANet Extension Cable can support a maximum of two display units and one sonar unit.
- The maximum length of cable from the CANet Extension Cable to the sonar or display units is 6 ft.
- Refer to the chartplotter's installation instructions for wiring the GPS 17 sensor and other devices.
- Ground the drain wire on the first display unit. Do not ground the drain wire on the subsequent display units or the sonar unit.
- The CANet Extension Cable Black wire is reserved for future use. When inserting a CANet unit on the CANet Extension Cable, reconnect all wires according to their color.

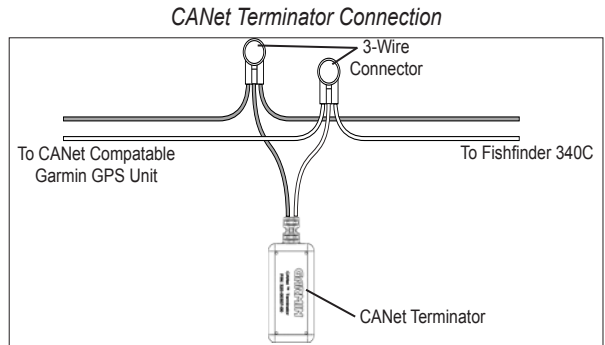
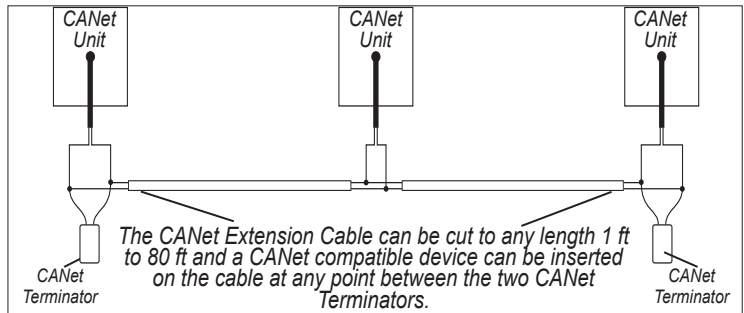
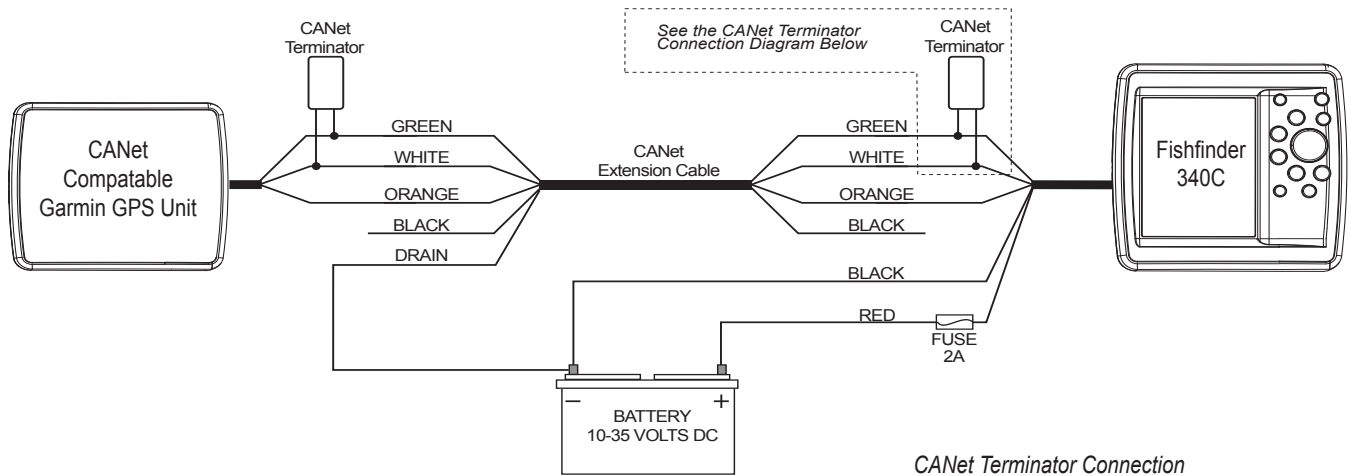

Fishfinder 340C CANet Wiring Diagram

Testing the Installation

While it is possible to perform some checks with the boat trailered, the boat should be in the water to properly test the sonar portion of the installation.

To test the installation:

1. Press and hold the **Power/Backlight** key until the Fishfinder beeps. It should turn on. If the Fishfinder fails to turn on, verify that the wiring adapter is properly connected in the back of the Fishfinder, the Red and Black wires are connected to the correct polarity, and that the 3-Amp fuse is installed and not blown. If the Fishfinder is connected to a power supply that exceeds safe operating levels, a “Battery voltage is too high” warning appears and the Fishfinder turns off in 10 seconds. If the Fishfinder does not detect a transducer, it automatically enters Simulator mode (see [page 42](#)).
2. When the Fishfinder detects a transducer at initial start up, a Select Transducer Type window appears. Press **ENTER** to select the transducer type.
3. Use the **ROCKER** to select your transducer type, and press **ENTER**.
4. Press **QUIT** to return to the Sonar Page.



NOTE: When adjusting the depth of the transducer, make the adjustments in small increments. Placing the transducer too deep can adversely affect the boat’s performance and put the transducer at greater risk of striking underwater objects.

Because water is necessary to carry the sounder’s sonar signal, the transducer must be in the water to work properly. It is not possible to get a depth or distance reading when out of the water. As the Fishfinder turns on, it should immediately start showing the bottom. Verify that the Fishfinder is not in Simulator mode. If the Fishfinder is in Simulator mode, make sure that the transducer is connected properly to the Fishfinder. When you place your boat in the water CHECK FOR LEAKS around any screw holes that have been added below the water line. DO NOT leave your boat in the water for an extended period of time without checking for leaks.

To test the transom mount installation:

1. Begin testing the installation at a slow speed. If the sonar appears to be working properly gradually increase the boat’s speed observing the sonar’s operation. If the sonar signal suddenly is lost or the bottom return is severely degraded, note the speed at which this occurs.
2. Return the boat to the speed at which the signal was lost. Make moderate turns in both directions, and see if the signal improves.
3. If the signal strength improves while turning, adjust the transducer so that it extends another 1/8” below the transom of the boat. It might take several adjustments to eliminate the degradation.
4. If the signal does not improve, it might be necessary to move the transducer to a different location.

USING THE FISHFINDER 340C

If you are turning on your Fishfinder 340C for the first time, use the following procedure. If you have already turned on your Fishfinder, and you are just familiarizing yourself with the basic functions, please go to “Learning the Basic Functions” on this page.

To start your Fishfinder for the first time:

1. Press and hold the **Power/Backlight** key until the Fishfinder beeps. It should turn on. If the Fishfinder fails to turn on, verify that the wiring adapter is properly connected in the back of the Fishfinder, the Red and Black wires are connected to the correct polarity, and that the 3-Amp fuse is installed and not blown. If the Fishfinder is connected to a power supply that exceeds safe operating levels, a “Battery voltage is too high” warning appears and the Fishfinder turns off. If the Fishfinder does not detect a transducer, it automatically enters Simulator mode (see [page 42](#)).
2. When the Fishfinder detects a transducer at initial start up, a Select Transducer Type window appears. Press **ENTER**.
3. Use the **ROCKER** to select your transducer type, and press **ENTER**.
4. Press **QUIT** to return to the Sonar Page.

Learning the Basic Functions

To turn the Fishfinder on or off:

Press and hold **Power/Backlight** to turn the Fishfinder on or off.

To change the software language on the screen:

1. Press and hold **ADJ/MENU**. The Main Menu appears.
2. Use the **ROCKER** to select the **System** tab. Then use the **ROCKER** again to select the **Language** field. Press **ENTER**.
3. Press up or down on the **ROCKER** to select a language. Press **ENTER**. All text on the Fishfinder appears in the chosen language.

To change the backlight setting:

1. Press and release **Power/Backlight** to show the backlight slider. The backlight slider disappears when idle for 20 seconds.
2. Press up or down on the **ROCKER** to change the user-set backlight setting. Press and release **Power/Backlight** to toggle the backlight setting between maximum, user-set, and minimum brightness levels.
3. Press **ENTER** to return to the previous page.

Using the Fishfinder 340C Keypad

Power/Backlight Key

- Press and hold to turn the unit on or off.
- Press and release to cycle through the maximum, user-set, and minimum backlight brightness levels.

PAGE Key

- Press to cycle through the main pages in sequence.

QUIT Key

- Press to cancel data entry or exit a menu.

ENTER Key

- Press to enter highlighted items and confirm on-screen messages.
- Press to mark a waypoint at the pointer position when in Pointer mode (when connected to a compatible NMEA GPS device).

ADJ/MENU Key

- Press to open the Adjustment Menu.
- Press and hold to open the Main Menu.



RANGE Keys

- Press to view the Range Menu and select a setting.

ROCKER Key

- Press to move through menus, highlight fields, enter data, or move the pointer.
- Press to change the current adjustment.

GAIN Key

- Press to view the Gain Menu, and then use the **ROCKER** to select a setting.

PAUSE Key

- Press to pause a Sonar or Flasher Page.
- Press and hold to enter Pointer mode.

DATA/CNFG Key

- Press to toggle the data fields in the upper-left corner of the page between the basic and advanced configurations.
- Press and hold to enter advanced data setup.

Understanding the Main Pages

The Fishfinder 340C typically offers several main pages for you to use, including the Sonar Page, Flasher Page, and Numbers Page.

If you are using a dual frequency transducer, and you have the Frequency set to **Dual**, the following pages are available instead: Split Sonar (200 kHz and 50 kHz), Sonar (200 kHz), Sonar (50 kHz), and Numbers.

To change the page:

1. Press **PAGE**. The Pages Menu appears.
2. Press **PAGE** or the **ROCKER** to select the page to which you want to go. The Pages Menu disappears after a few seconds.

Depending on the current page, you can access page-specific information, including one or more of the following:

- Access the Main Menu by pressing and holding the **ADJ/MENU** key (see [page 26](#)).
- Access the Adjustment Menu by pressing and releasing the **ADJ/MENU** key (see [page 35](#)).
- Access the advanced data configuration options by pressing and holding the **DATA/CNFG** key (see [page 37](#)).

Using the Sonar Pages

The Sonar Page that you see and the options that appear in its Adjustment Menu depend on the transducer and settings that you are using.

If you are using a dual beam transducer, you can access the basic Sonar Page and its related Adjustment Menu.

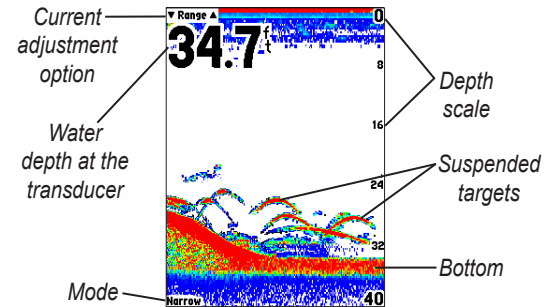

Sonar	
Range	(Auto)
Gain	(Auto)
Color Gain	(Auto)
Whiteline	(Off)
Beam	(Narrow) ▶
Ultrasroll™	(100%)
Depth Line	(Off)
Zoom	(Off)
Tools	▶
Split When Zoomed	(Off) ▶

If you are using a dual frequency transducer and you set the Frequency to **Dual**, you can access the Split Sonar Page, the Sonar (220kHz) Page, the Sonar (50kHz) Page, and its related Adjustment Menu.

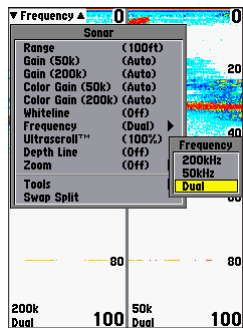

Split Sonar Page with Adjustment Menu

For all Sonar Pages, the currently selected adjustment option (see [page 35](#)) appears in the upper-left corner of the screen. Directly below the adjustment option, the screen shows numeric data, such as **Depth**, **Water Temperature**, or **Water Speed**, depending on your settings (see [page 37](#)). The middle of the page contains a right-to-left moving sonar image of the water beneath your boat. Items appear as they pass under your transducer. Items on the right side of the screen are closer to you than those on the left.

Along the right side of the screen is a scale that reflects the depth of the area shown.

The most intense solid colors indicate the strongest sonar returns (red is the default). The weakest sonar returns appear in the least intense color (blue is the default).

For more information on understanding the sonar, read the Getting Started section of this manual (see [page 2](#)).

Using Split When Zoomed

You can set your Fishfinder to split the screen every time use the Zoom option on a full-screen Sonar Page.

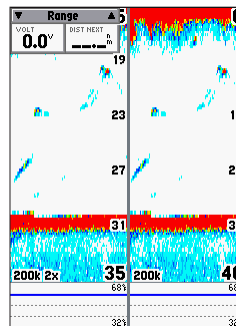

To split the screen:

1. From a Sonar Page, press **ADJ/MENU**. The Adjustment Menu appears.
2. Use the **ROCKER** to select **Split When Zoomed**, and press **ENTER**.
3. Use the **ROCKER** again to select **On**, and press **ENTER**. The current page is now a split screen.

If the Zoom option was set to **Off**, the last used Zoom setting is used for one side of the split screen, and the other side of the screen is not zoomed. If the screen does not split, select a setting other than **Off** for the Zoom option.

If Zoom contains a setting other than **Off**, the current Zoom setting is used for half of the screen, and the other side is not zoomed.

Using the Flasher Page

If you prefer the appearance of flasher sonars, use the Flasher Page. It provides an almost instantaneous return of what is below your boat. See “Using the Adjustment Menu” on [page 35](#) for information about the settings and how to change them.

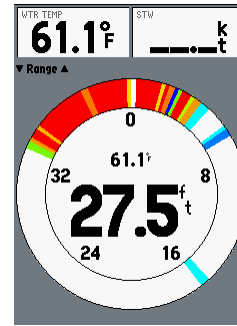

The most intense, constant signal on the Flasher Page is the actual depth and bottom:

- A **soft bottom** (such as silt or mud) creates a signal that is narrow and more faint.
- A **hard bottom** (such as sand or rock) creates a signal that is wider.

The colors indicate the different strengths of the signals.

Using the Numbers Page

When you use the Numbers Page, you can view three data fields of your choice. (See “Configuring Advanced Data Fields” on [page 37](#) for more information about the data fields.)

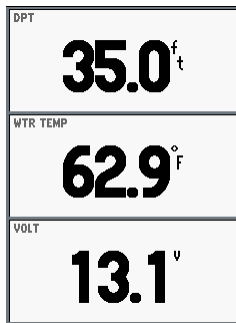

To change the data fields on the Numbers Page:

1. From the Numbers Page, press and hold **DATA/CNFG**. The Data Configuration Menu appears.
2. Use the **ROCKER** to select the field that you want to change, and press **ENTER**. A menu of your option categories appears.
3. Use the **ROCKER** to select the category and data field that you want to appear on the screen in that position, and press **ENTER**.
4. Make all changes. When you are finished, press **QUIT**.

Using the Main Menu

The Main Menu contains the Fishfinder settings that should not require frequent change. The Main Menu is divided into the following tabs: Graph, Sonar, Temp, Alarms, System, Units, and Time. Each tab is described in more detail in this section.

To view or change a setting in the Main Menu:

1. Press and hold **ADJ/MENU**. The Main Menu appears.

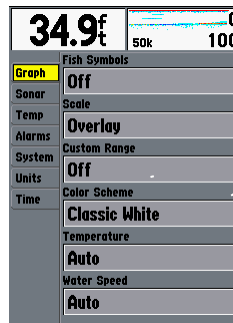

2. Highlight the tab for the option you want to view or change.
3. Highlight the setting you want to change, and press **ENTER**. The available settings appear.
4. Highlight the setting you want, and then press **ENTER**. The new setting is now active.

Your changes to the Main Menu settings are used until you go to the Main Menu and set the System Factory Settings option to **Yes**.

Graph Tab

The Graph tab enables you to determine the appearance of the Sonar Pages.

The following settings are available:

- **Fish Symbols**—sets how the Fishfinder interprets suspended targets and background information. If you select a fish symbol, the Fishfinder identifies some returns for you by replacing them with fish symbols (in large, medium, and small sizes based on the size of the sonar return). If you are using dual beam, fish symbols from the narrow beam (directly underneath your boat) are solid, and the returns from the wide beam (out to the sides of your boat) are hollow.

 (default) the Fishfinder does not interpret the sonar return data.

 suspended targets appear as symbols. No background information appears.

 suspended targets appear as symbols with no background information shown. The target depth is indicated.

 suspended targets appear as symbols. Background information appears, making the distinction between fish and structure easier.

 suspended targets appear as symbols with background information shown. The target depth is indicated.

- **Scale**—controls the depth scale shown vertically along the right side of the graph. The settings are **Overlay** (default), in the **Corners**, **Basic** scale, or **No Scale**.
- **Custom Range**—allows you to specify a custom viewing range or scale. When **On**, this range appears as **Custom** in the Range setting. The left value is the top of the scale and the right value is the bottom of the scale.
- **Color Scheme**—sets the colors for the Sonar and Flasher Pages. The default setting is **Classic White**.
- **Temperature and Water Speed**—hides or shows temperature and water speed on the Sonar Page. When set to **Auto**, the Fishfinder automatically shows this information if it is received from a capable transducer.

Sonar Tab

Use the Sonar tab to set up initial settings and calibrations.

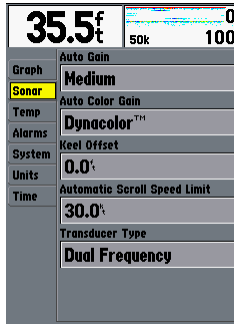

The following settings are available:

- **Auto Gain**—controls the aggressiveness of the Auto Gain when the Gain option is set to **Auto** (see [page 35](#)). The higher the setting, the greater the number of targets appear on the screen. The lower the setting, the less clutter on the screen. The settings are **Low**, **Medium** (default), and **High**.
- **Auto Color Gain**—controls what colors are applied to the objects on the screen when the Color Gain option is set to **Auto** (see [page 35](#)). **Color DCG** is based on depth and makes it easier to spot subtle changes in bottom conditions or fish sizes. **DynaColor™** (default) represents the latest

in sonar data presentation and is recommended for all applications. The presentation is based on bottom strength. It makes the bottom and the fish easier to see and requires fewer adjustments.

- **Keel Offset**—allows you to offset the surface reading for the depth of a keel. This makes it possible to measure depth from the bottom of your keel instead of from a transducer’s location near the water line. Enter a positive number to offset for a keel. You can also enter a negative number to compensate for a large vessel that may draw several feet of water, requiring the transducer to be submerged if you want to measure from the water line. The Keel Offset is reflected in the depth reading.
- **Automatic Scroll Speed Limit**—automatically adjusts the scroll rate (see [page 36](#)) with the speed of your vessel when the Scroll option is set to **Auto** (if equipped with a speed sensor or receiving GPS NMEA input). Entering your maximum cruising speed produces a 100% scroll rate when you reach that speed. One half of that speed produces a 50% scroll rate, and so on. The default is **30.0 kt**.
- **Transducer Type**—allows you to specify what type of transducer you are using.

- **Calibrate Water Speed**—this appears only if you are using a speed-capable transducer/sensor. Calibration is required to ensure that the water speed shown on your Fishfinder is accurate. The Fishfinder automatically uses GPS ground speed (if available using NMEA input) for comparison on the calibration. If a GPS ground speed is not available, use either your boat's speedometer reading (not always accurate) or a stopwatch to determine your speed over a certain distance (distance / time = speed). It is recommended that the calibration take place in water having little or no current.



NOTE: If the boat is not moving fast enough or the speed sensor is not registering a speed, a “Boat Is Not Moving Fast Enough To Calibrate” message appears at the bottom of the screen. Check that the speed sensor wheel is moving or safely increase boat speed. If there is a problem with the Fishfinder speed sensor, or if a speed sensor is not installed, a “Water Speed Sensor Is Not Working” message appears at the bottom of the screen. Check the connections of the speed sensor cables.

To calibrate the water speed:

1. Use the **ROCKER** to highlight **Calibrate Water Speed**, and press **ENTER**.
2. Bring the boat to a cruising speed. Both the top GPS ground speed and uncalibrated water speed appears at the bottom of the calibration window. Note your top speed, then stop the boat, and press **ENTER**.
3. By default, the top speed automatically appears in the **What was your top water speed?** field. If a ground speed is not available, the top uncalibrated water speed is used instead. If the new speed is correct, highlight **OK**, and press **ENTER**. If you want to manually enter a calibration, press **ENTER** on the speed field, enter a new speed, and press **ENTER**.

Temp (Temperature) Tab

Use the Temp tab to control the temperature log (if your boat is equipped with a temperature transducer/sensor). The graph reads from right to left, so that the most recent temperature measured appears on the far-right side of the log. The dotted lines within the graph indicate intervals in the temperature scale and the duration of time.

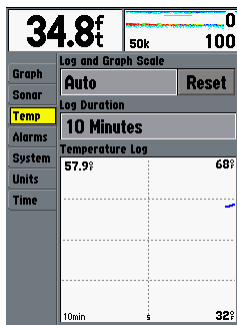

The following settings are available:

- **Log and Graph Scale**—sets the temperature range (in degrees) for viewing on the log and on the Sonar Pages. Select **Auto** to have the Fishfinder automatically determine the best range, or select a Span of **2, 4, 6, 8, or 10** degrees.

- **Log Duration**—sets how fast or slow the temperature log scrolls; the shorter the time duration, the faster the temperature log scroll. Select a duration from **1 Minute** to **2.5 Hours**. **10 Minutes** is the default.
- **Temperature Log**—records the water temperature as you move through the water, so that you can look for temperature changes over a period of time.

Alarms Tab

The Alarms tab contains settings for the Fishfinder’s alarms. (For a list of alarms and unit messages, see [page 43](#).) The Alarm tab is divided into two sub tabs: Sonar alarms and System alarms.

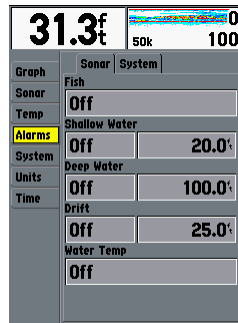

To set an alarm:

1. Use the **ROCKER** to highlight a sub tab of the Alarms tab.
2. Highlight the field below the alarm name that you want to set, and press **ENTER**.
3. Highlight a new setting, and press **ENTER**.
4. Highlight the next field to the right (if applicable), and press **ENTER**. Then enter a setting, and press **ENTER** to finish.

Sonar Sub Tab

- **Fish**—sets an alarm to sound (and an icon to appear) when the Fishfinder detects a fish of the specified size.
- **Shallow Water** and **Deep Water**—set alarms to sound when you enter an area of specified depth that is too shallow or too deep. The settings are **Off** (default) and a user-defined number.
- **Drift**—sets an alarm to sound when you exceed a specified drift depth range. For example, if the value is set to 5 feet and the current depth is 20 feet when the alarm is enabled, the alarm sounds if the Fishfinder detects a depth greater than 25 feet or shallower than 15 feet.
- **Water Temp**—sets an alarm to sound when the transducer reports a temperature either above, below, inside, or outside the specified values.

System Sub Tab

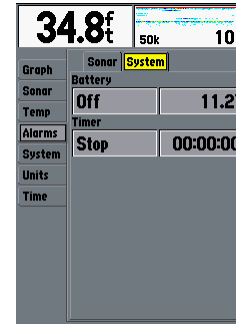

- **Battery**—sets an alarm to sound when the battery is reaching a critical state of discharge. The settings are **Off** (default) and a user-defined number of volts remaining.
- **Timer**—allows you to control a timer. This can be useful for tournament fishing. The settings are **Count Dn** (Down), **Count Up** (Up), **Stop**, or **Reset** the timer.

System Tab

The System tab enables you to control various system and interface settings.



The following settings are available:

- **Beeper**—controls all sounds. Select from **Off**, **Alarms Only** (sounds for alarms/messages), or **Key and Alarm** (sounds for key presses and alarms/messages).
- **Language**—select from various languages for the Fishfinder’s on-screen display.
- **System Mode**—lets you simulate Fishfinder operation. If the Fishfinder does not detect a transducer, it automatically enters Simulator mode.

- **NMEA Input/Output**—controls the input and output of NMEA 0183 version 3.01 data to and from the Fishfinder. This setting must be **On** to receive GPS navigational data and send Sonar NMEA data. See [page 16](#) for details on available NMEA sentences.
- **Factory Settings**—restores all settings to the original factory default values. The Fishfinder 340C turns off and back on again when you select **Yes**.
- **Software Version**—shows the Fishfinder’s software version, copyright date, and unit ID.
- **Reset Odometer**—this option appears only if you are using a speed-capable transducer/sensor. This resets the odometer field to zero.

Units Tab

The Units tab enables you to define the units of measure.

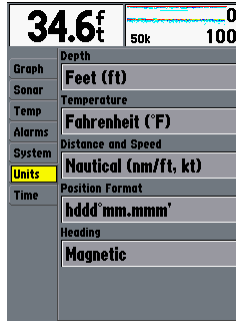

The following settings are available:

- **Depth**—lets you select the units of measure for depth in **Feet (ft)**, **Fathoms (fa)**, or **Meters (m)**.
- **Temperature**—lets you select the units of measure for temperature in **Fahrenheit (°F)** or **Celsius (°C)**.
- **Distance and Speed**—lets you select the units of measure for distance and speed readouts in **Nautical (nm/ft, kt)**, **Nautical (nm/m, kt)**, **Statute (mi, mh)**, or **Metric (km, kh)**.
- **Position Format**—changes the coordinate system in which a position reading appears. The default format is latitude and longitude in degrees, minutes, and thousandths of a minute

(**hddd°mm.mmm'**). The following additional formats are available: latitude/longitude in decimal degrees (**hddd.ddddd°**) and latitude/longitude in degrees, minutes, and seconds (**hddd°mm'ss.s''**).

- **Heading**—sets the reference used in calculating heading information for the Bearing, Compass, Course, and Track Advanced Data fields (see [page 37](#)). **True** shows data with reference to True North. **Magnetic** shows data with reference to Magnetic North using the magnetic variation value received in the RMC NMEA sentence (see [page 16](#)).

Time Tab

Use the Time tab to show the current time and date, adjust the 12 or 24-hour time format, enter a time zone, and adjust for daylight saving time to show correct local time. The time appears only if you are receiving valid NMEA input from a GPS unit (see [page 16](#)) or if the Fishfinder is in Simulator mode.

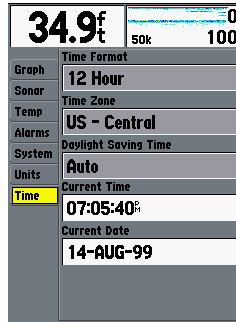

The following settings are available:

- **Time Format**—lets you choose from **12-hour**, **24-hour** (military), or **UTC** (also called Greenwich Time) format.
- **Time Zone**—lets you choose your time zone to show the correct local time.
- **Daylight Saving Time**—lets you choose from **Auto** (not always available), **On**, or **Off** to adjust for daylight saving time.
- **Current Time** and **Current Date**—shows the current time and date. These fields are blank if the Fishfinder is not receiving a time from an attached GPS. You cannot edit these fields.

Using the Adjustment Menu

The Adjustment Menu gives you direct access to the most commonly used settings and features. The Adjustment Menu also provides a quick review of how the sonar is configured. This menu varies depending on your transducer type, your current page, and your current settings. You can make all adjustments by using the **ROCKER** and the **ENTER** key.

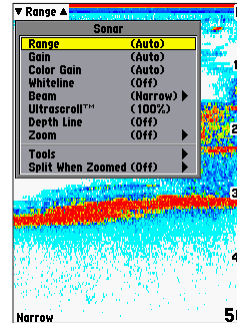

To change an Adjustment Menu setting:

1. Press **ADJ/MENU**. A list of all options and their current settings appears. The Adjustment Menu automatically disappears when idle for 20 seconds, or you can press **ADJ/MENU** to exit.
2. Press the **ROCKER** to select the option that you want to change, and then press **ENTER** to show the settings. The current setting is highlighted in yellow.
3. Press the **ROCKER** to select a new setting.
4. Press **ENTER** to accept the new setting and return to the Sonar Page.

The current adjustment option appears in the upper-left corner of the screen. For fast adjustment from a Sonar Page, press left or right on the **ROCKER** to scroll through the options. Press up or down on the **ROCKER** to change the current setting, or press **ENTER** to review the setting before you make changes.

Available adjustments are:

- **Range**—sets the screen depth range used for viewing. **Auto** (recommended) automatically tracks the bottom, or you can set a specific depth range (making sure the range includes the bottom of the water).

- **Gain**—controls the sensitivity of the Fishfinder's sonar receiver. **Auto** (default) is the recommended setting. It automatically sets the sonar sensitivity. You can also set the gain manually. To see more detail on the screen, increase the receiver sensitivity by selecting a higher gain. If there is too much detail or if the screen is cluttered, lower the sensitivity (lower the gain) to increase the clarity of the screen. If Frequency is set to **Dual**, you can set the Gain separately for each frequency (50 kHz and 200 kHz).
- **Color Gain**—controls what colors are applied to the objects on the screen. **Auto** (default) is the recommended setting. It automatically sets the colors, based on your Auto Color Gain setting. You can also set the Color Gain manually. If Frequency is set to **Dual**, you can set the Color Gain separately for each frequency (50 kHz and 200 kHz).
- **Beam**—only appears when using a dual beam transducer. This controls the angle of the transducer beam. **Wide** beam allows you to see more fish in shallow water, even off the sides of the boat. You can also choose **Narrow** (default) beam.
- **Whiteline**—can make it easier to identify the hardness of the bottom (hard or soft). This setting adjusts a brightly-colored highlight of the strongest signal area of the bottom.

Off (default)—all high-intensity bottom returns appear as a solid color.

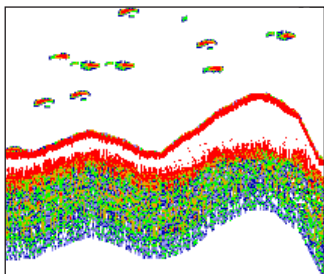

Whiteline Turned On

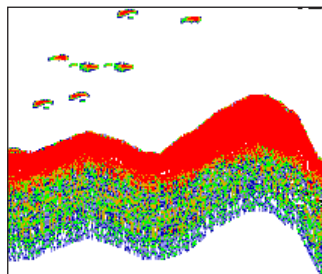

Whiteline Turned Off

On—the strongest signal from the bottom appears as a bright color.

- **Frequency**—only appears when using a dual frequency transducer. This allows you to choose a sonar operation frequency. You can choose **200 kHz**, **50 kHz**, or **Dual** frequency (to alternate between the two frequencies).
- **Scroll**—adjusts the rate at which the Sonar Pages scroll from right to left. **Ultrascroll** (default) is used when you select a scroll rate from **90%** to **100%**. **Auto** automatically adjusts the scroll rate according to the boat's speed. (See also "Automatic Scroll Speed Limit" on [page 28](#).)

- **Depth Line**—adds a horizontal depth line across the screen that is used to measure the depth of underwater objects. The depth of the line appears on the right side of the line. Press up or down on the **ROCKER** to control the position of the line on the Sonar Pages. Move the slider to the top to turn off Depth Line.
- **Zoom**—sets a screen zoom scale. The following settings are available:
 - Off**—turns off the Zoom function.
 - 2x Zoom**—increases the graph zoom level 2x.
 - 4x Zoom**—increases the graph zoom level 4x.
- **Btm (Bottom) Lock**—sets the Bottom Lock (returns from the bottom up) picture. When using this setting, "BL" appears at the bottom of the screen.
- **Zoom View**—available when you select a Zoom scale other than **Off**. You can use the Zoom View setting to change the viewing range of a zoomed display. **Auto** follows the water bottom. If you select **Bottom Lock**, use the **Span** setting to adjust how far off the bottom the Fishfinder shows data.

- **Tools**—controls the appearance of useful sonar tools. The following options are available:

A-scope—when you turn on A-scope, a vertical flasher bar appears on the far-right side of the screen. This flasher indicates structure and bottom returns much the same as the Flasher Page. The horizontal width of the A-scope signal indicates the strength of the signal.

Color Bar—shows a gradient scale of the current Color Gain setting (see [page 35](#)).

Temp Graph—appears only if you have a temperature-capable transducer. This setting toggles the temperature graph along the bottom of a Sonar Page on or off. When on, the temperature graph matches the scrolling data.

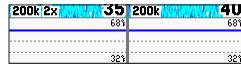

- **Split When Zoomed**—splits the screen when you use the Zoom option. If you turn on Zoom, then this setting splits the screen. If Zoom is **Off** and you turn on **Split When Zoomed**, the last used zoom level is used on the screen.
- **Swap Split**—available on the Split Sonar Page when Frequency is set to **Dual**. This switches on which side the frequencies appear.

Configuring Advanced Data Fields

The top-left corner of the screen contains configurable data fields for the Sonar Pages. You can view basic or advanced data for these data fields. By default, the Basic configuration shows the depth, water temperature, and speed (depending on the Graph tab settings and the type of transducer or sensors attached). The Advanced configuration shows a larger, configurable data field with a white background. The Advanced Data Setup Menu allows you to specify the type of data shown and either a **Narrow** (small) or **Wide** (larger) size format for each data field.

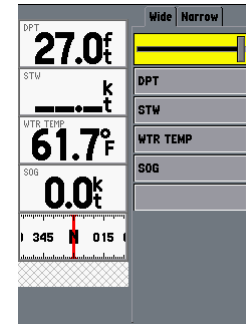
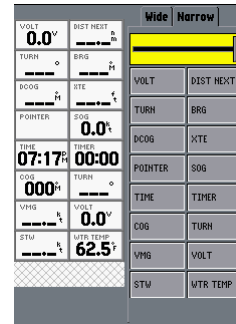

The following selections require the proper NMEA data to view information in a data field: Bearing, Compass, Course, Distance to Next, Off Course, Pointer, Position, Speed, Time Of Day, Track, Turn, and VMG. You must turn on NMEA Input/Output to receive this data (see [page 32](#)).

To toggle the data field appearance:

Press and release the **DATA/CNFG** key to alternate between the Basic and Advanced data field configurations.

To change or add an advanced data field:

1. Press and hold the **DATA/CNFG** key to access the Advanced Data Menu. The current configuration appears on the left side of the screen. The available data field options appear on the right side.
2. Use the **ROCKER** to select the **Wide** or **Narrow** tab.
3. Press down on the **ROCKER** to select the slider. Then press left or right to determine the quantity of fields of that size.
4. Press down on the **ROCKER** to select a field that you want to change. Press **ENTER** to see your choices. Press **ENTER** again to select your choice. Your choice appears as a new data field. Repeat this step for each field you want to change.
5. When you are finished, press **QUIT** to exit the Advanced Data Menu. Your new choices appear on the screen.

Data Field Definitions

BRG (bearing)—the compass direction from a location to a destination, measured to the nearest degree. When using a GPS receiver, bearing usually refers to the direction to a waypoint from your current location.

COG (course over ground)—your direction of movement relative to a ground location.

DCOG (desired course over ground)—the compass course between the “from” and “to” waypoints.

DIST NEXT (distance to next)—the length from your current location to the next waypoint.

DPT (depth)—the depth of the water



NOTE: If the Fishfinder is unable to track the bottom for any reason, the digits which indicate depth flash on and off to alert you that the Fishfinder is not tracking the bottom.

POINTER—an arrow that points toward a destination waypoint from your current position (BRG). This field requires NMEA input.

SOG (speed over ground)—the actual speed that the GPS unit is moving over the ground. This field requires NMEA input.

STW (speed through water)—the speed as calculated by an optional speed sensor on the transducer.

TIME—the time of day, shown using your selected time format.

TIMER—an alarm that counts down or up in the increments that you set in the Alarms System sub tab.

TURN—the degrees that you must turn left or right to make your direction of travel match your bearing. Steer left (L) or right (R) until this reads **0** to go directly to your destination.

VMG (velocity made good)—the rate of closure to a destination based on your current speed and course.

VOLT—the current battery voltage input.

WTR TEMP (water temperature)—the water temperature at the transducer.

XTE (crosstrack error)—how far off the chosen course you are, measured by your selected distance units. This indicates if you are to the left or right of the course.

Pausing a Sonar or Flasher Page

Use a paused screen to take a better look at sonar returns. The depth continues to update while the page is paused, but the Fishfinder does not show any new sonar data until the Sonar Page resumes scrolling. You might see a discontinuity from where the sonar information stops to where it starts again when you resume scrolling the screen.

To pause and unpaue the Sonar or Flasher Page:

From the Sonar or Flasher Page, press **PAUSE** to stop the scrolling. Press **PAUSE** again (or **QUIT**) to resume scrolling.

Marking a Waypoint

You can use Pointer mode to move a cursor around on the paused Sonar Page to reference sonar items and mark waypoints for that location (if your Fishfinder is attached to a Garmin GPS or compatible NMEA navigation device; see [page 16](#)). When you use Pointer mode, a data field appears at the top of the graph with the cursor's depth, surface temperature for that location, and GPS coordinates (if available). This makes it easy to save the location of an underwater object (such as a stump, rock, or brush pile), which you can navigate back to with your GPS receiver.

To enable NMEA input/output:

1. Press and hold **ADJ/MENU**. The Main Menu appears.
2. Use the **ROCKER** to select the **System** tab.
3. Use the **ROCKER** to select the **NMEA Input/Output** field. Press **ENTER**.
4. Use the **ROCKER** to select **On**. Press **ENTER**. **On** appears in the field.
5. Press **QUIT** to return to the previous page.

To start or stop Pointer mode on a Sonar Page:

1. From a Sonar Page, hold **PAUSE** for two seconds. The Fishfinder is now in Pointer mode.
2. Use the **ROCKER** to move the cursor around on the screen. Information about the Pointer location appears on the screen.
3. Press **QUIT** to resume normal scrolling.

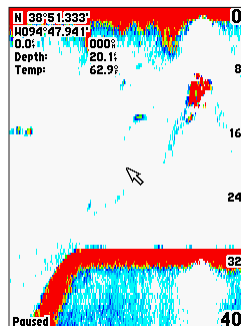

To mark an underwater waypoint:

1. Make sure that your Garmin GPS or compatible NMEA navigation device is properly attached and the **NMEA Input/Output** is **On** (see [page 32](#)).
2. From a Sonar Page, press and hold **PAUSE** to enter Pointer mode and pause the screen movement.
3. Use the **ROCKER** to move the cursor onto the target (for example, an underwater drop off or stump) that you want to mark. Data appears with the GPS coordinates, depth, and surface temperature for that location.
4. Press **ENTER**. The New Waypoint Window appears with a default four-digit name and the pointer's coordinates automatically filled in.

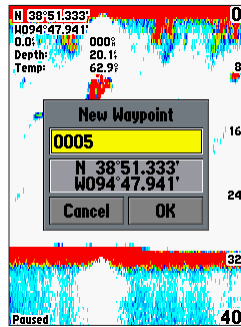

5. To change the name, highlight the name field, and press **ENTER**.
6. Make your changes using the **ROCKER**. (Alphabetic and numeric characters are available.) Press **ENTER** when you are finished.
7. Use the **ROCKER** to move the field highlight to **OK**, and press **ENTER**. The Fishfinder then sends a NMEA WPL sentence to an attached GPS unit or NMEA navigational device.

APPENDIX

Specifications

Physical Specifications

Size: 6.2" H x 6.3" W x 3.1" D (15.8 cm x 16.0 cm x 8.3 cm)

Weight: 2.25 lbs. (1.02 kg)

Display: 5.0" diagonal (12.7 cm), 4.0" H x 3.0" W, 256-color TFT display with adjustable brightness (234 x 320 pixels)

Case: Fully gasketed, high-impact plastic alloy, waterproof to IEC 529 IPX7 standards

Temp. Range: 5°F to 131°F (-15°C to 55°C)

Power

Source: 10-33v DC

Usage: 17 watts max. at 10v DC; 15 watts at 13.8v DC nominal

Fuse: AGC/3AG - 3.0 Amp

Sonar

Power: Dual frequency, 500 watts (RMS), 4,000 watts (peak to peak); Dual beam, 400 watts (RMS), 3,200 watts (peak to peak)

Frequency: 50/200 kHz (dual frequency), 80/200 kHz (dual beam)

Depth: 1,500 feet (dual frequency), 900 feet (dual beam)

(Depth capacity is dependent on water salinity, bottom type, and other water conditions.)

Using Simulator Mode

You can use Simulator mode to practice and learn the operation of the Fishfinder. If the Fishfinder does not detect a transducer, it automatically starts in Simulator mode.

While in Simulator mode, the Fishfinder shows a bottom scene, and you can control the Fishfinder (except the Gain and Auto Gain options). If no keys are pressed for two minutes, the Fishfinder automatically resets to default settings while in Simulator mode.

To exit Simulator mode, turn off the Fishfinder.

Optional Accessories

Purchase the following optional accessories on the Garmin Web site:

Quick-release flush mount kit—mounts your Fishfinder flush on the bulkhead or cabin wall. Press the side clips to release the Fishfinder so you can take it with you.

CANet™ connection kit—allows you to connect your Fishfinder 340C to CANet-capable Garmin chartplotters, so you can read sonar displays on chartplotters located elsewhere in the boat.

Go to www.garmin.com for the following information:

- The most recent list of available accessories.
- Documentation updates.

Messages and Alarms

The Fishfinder 340C uses an on-screen pop-up message system to alert you to unit operating characteristics. When a message appears, press **ENTER** to acknowledge the message and return to the page you were viewing.

Anchor Drag Alarm—you have drifted out of the specified distance range.

Battery Alarm—battery voltage has fallen below the value entered in the Battery Alarm setup.

Battery Voltage Is Too High—too much input voltage; the unit shuts off in 10 seconds. Decrease the input voltage to 33 volts or less.

Boat Is Not Moving Fast Enough to Calibrate—the boat is not moving fast enough for the speed wheel to provide a valid speed.

Can't Read Voltages That High, Limited to Top of Range—the voltage value in the Battery Alarm setup is higher than the unit can read.

Can't Read Voltages That Low, Limited to Bottom of Range—the voltage value in the Battery Alarm setup is lower than the voltage where the unit automatically turns off.

Can't Send Waypoint—the unit cannot transmit the waypoint using the NMEA WPL sentence. Check the wiring.

Deep Water Alarm—the Deep Water Alarm depth has been reached.

Drift Alarm—the depth has changed by the amount of the Drift Alarm value.

Fish Alarm—an icon appears and a beep sounds (if enabled) when a fish is detected. This alarm does not show a message banner.

NMEA Depth Is Below Transducer—you must enter an appropriate Keel Offset for the transducer.

Shallow Water Alarm—the Shallow Water Alarm depth has been reached.

Simulating Operation—the unit is in Simulator mode. This message reappears after 2 minutes of inactivity. (If the unit does not detect a transducer attached, it automatically enters Simulator mode.)

Sonar Failed, Unit Needs Repair—there is an internal problem with the Fishfinder. Contact your dealer or Garmin Product Support to have the unit serviced.

Timer Alarm—the Timer Alarm value has counted down to 00:00:00.

Transducer Disconnected, Sonar Turned Off—there is not a transducer attached, bad cable/transducer, or the transducer cable was disconnected. If the transducer cable is removed while the unit is on, reconnect and cycle power.

Water Speed Sensor Is Not Working—the speed sensor is not detected. Check the connections.

Water Temperature Alarm—the Water Temperature Alarm setting has reached a value above, below, inside, or outside of the specified values.

Limited Warranty

This Garmin product is warranted to be free from defects in materials or workmanship for one year from the date of purchase. Within this period, Garmin will at its sole option repair or replace any components that fail in normal use. Such repairs or replacement will be made at no charge to the customer for parts or labor, provided that the customer shall be responsible for any transportation cost. This warranty does not cover failures due to abuse, misuse, accident or unauthorized alteration or repairs.

THE WARRANTIES AND REMEDIES CONTAINED HEREIN ARE EXCLUSIVE AND IN LIEU OF ALL OTHER WARRANTIES EXPRESS OR IMPLIED OR STATUTORY, INCLUDING ANY LIABILITY ARISING UNDER ANY WARRANTY OF MERCHANTABILITY OR FITNESS FOR A PARTICULAR PURPOSE, STATUTORY OR OTHERWISE. THIS WARRANTY GIVES YOU SPECIFIC LEGAL RIGHTS, WHICH MAY VARY FROM STATE TO STATE.

IN NO EVENT SHALL GARMIN BE LIABLE FOR ANY INCIDENTAL, SPECIAL, INDIRECT OR CONSEQUENTIAL DAMAGES, WHETHER RESULTING FROM THE USE, MISUSE, OR INABILITY TO USE THIS PRODUCT OR FROM DEFECTS IN THE PRODUCT. Some states do not allow the exclusion of incidental or consequential damages, so the above limitations may not apply to you.

Garmin retains the exclusive right to repair or replace the unit or software or offer a full refund of the purchase price at its sole discretion. SUCH REMEDY SHALL BE YOUR SOLE AND EXCLUSIVE REMEDY FOR ANY BREACH OF WARRANTY.

To obtain warranty service, contact your local Garmin authorized dealer or call Garmin Product Support for shipping instructions and an RMA tracking

number. The unit should be securely packed with the tracking number clearly written on the outside of the package. The unit should then be sent, freight charges prepaid, to any Garmin warranty service station. A copy of the original sales receipt is required as the proof of purchase for warranty repairs.

Garmin International, Inc.
1200 E 151st Street, Olathe, Kansas 66062 USA
Tel. 913/397.8200
Fax. 913/397.8282

Garmin (Europe) Ltd.
Liberty House, Hounslow Business Park,
Southampton, Hampshire, SO40 9RB UK
Tel. +44 (0) 870.8501241 (outside the UK) or
0808 2380000 (UK only)
Fax +44 (0) 870.8501251

Online Auction Purchases: Products sold through online auctions are not eligible for rebates or other special offers from Garmin. Online auction confirmations are not accepted for warranty verification. To obtain warranty service, an original or copy of the sales receipt from the original retailer is required. Garmin will not replace missing components from any package purchased through an online auction.

International Purchases: A separate warranty is provided by international distributors for units purchased outside the United States. This warranty is provided by the local in-country distributor and this distributor provides local service for your unit. Distributor warranties are only valid in the area of intended distribution. Units purchased in the United States or Canada must be returned to the Garmin service center in the United Kingdom, the United States, Canada, or Taiwan for service.

The Garmin Fishfinder 340c has no user-serviceable parts. Should you ever encounter a problem with your unit, please take it to an authorized Garmin dealer for repairs.

The Fishfinders are fastened shut with screws. Any attempt to open the case to change or modify the unit in any way will void your warranty and may result in permanent damage to the equipment.

Declaration of Conformity

Hereby, Garmin declares that this Fishfinder 340c product is in compliance with the essential requirements and other relevant provisions of Directive 1999/5/EC.

To view the full Declaration of Conformity, see the Garmin Web site for your Garmin product:

<http://www.garmin.com/products/ff340c/>. Click Manuals and then select the Declaration of Conformity

Software License Agreement

BY USING THE FISHFINDER 340C, YOU AGREE TO BE BOUND BY THE TERMS AND CONDITIONS OF THE FOLLOWING SOFTWARE LICENSE AGREEMENT. PLEASE READ THIS AGREEMENT CAREFULLY.

Garmin grants you a limited license to use the software embedded in this device (the “Software”) in binary executable form in the normal operation of the product. Title, ownership rights, and intellectual property rights in and to the Software remain in Garmin.

You acknowledge that the Software is the property of Garmin and is protected under the United States of America copyright laws and international copyright treaties. You further acknowledge that the structure, organization, and code of the Software are valuable trade secrets of Garmin and that the Software in source code form remains a valuable trade secret of Garmin. You agree not to decompile, disassemble, modify, reverse assemble, reverse engineer, or reduce to human readable form the Software or any part thereof or create any derivative works based on the Software. You agree not to export or re-export the Software to any country in violation of the export control laws of the United States of America.

INDEX

Symbols

- 200 kHz frequency 2
- 2X zoom 36
- 50 kHz frequency 2

A

- A-scope 37
- accessories 1, 42
- adj/menu key 22
- adjustment menu 34
 - for the split sonar page 24
- alarms 30, 43
- alarms tab 30
- anti-reflective coating iii
- arches 4
- assembling the transducer 9
- automatic scroll speed 28
- auto color gain 28

B

- backlight key 22
- backlight setting 21
- basic display 37
- battery alarm 31
- beam 35
- bearing 38
- beeper 32
- bottom of the water 4

46

- bracket assembly 6
- brg (bearing) 38

C

- cables 5
- calibrate water speed 29
- CANet™ i
- case, cleaning the iii
- change a setting 26
- changing the data fields on the numbers page 26
- cleaning the case iii
- cleaning the screen iii
- clutter 4
- cnfg key 22
- cog (course over ground) 38
- color 4
- color bar 37
- color scheme 27
- contact Garmin iii
- current time and current date 34
- custom range 27

D

- data/cnfg key 22
- data fields 24, 26, 37
- date 34
- daylight saving time 34
- dcog (desired course over ground) 38
- Declaration of Conformity 45

- defaults 32
- definitions, data field 38
- depth 24, 33, 35, 37, 41
- depth line 36
- depth units 33
- distance units 33
- dist next (distance to next) 38
- dpt (depth) 38
- drift alarm 31
- dual beam 3
- dual frequency 2, 24

E

- enable NMEA input/output 40
- enter key 22
- extended data setup 37
- extended display 37

F

- factory settings 32
- field definitions 38
- fish alarm 31
- fish symbols 4, 27
- flasher page 25
- flush mounting the fishfinder 7
- frequency 36
 - 200 kHz 2
 - 50 kHz 2
- fuse 15, 42

G

- gain 35, 37
- gain key 22
- gain setting 4
- GPS, wiring to a 16
- graphs
 - auto gain 28
 - Whiteline 35
- graph tab 27

H

- hardness of the bottom 4
- hard bottom 25
- hard structure 4
- heading 33

I

- immersion, water iii
- input voltage 15
- installation 20
- installation, shoot-thru-hull 13
- installing
 - the unit on the mount bracket 7
 - the wiring harness 15
- installing the fishfinder 5
- interfacing 16

K

- keel offset 28
- keypad, using the 21, 22

L

language, changing the 21
 language selection 32
 LCD screen 5
 location for shoot-thru-hull installation 13
 location for the fishfinder 5
 log, temperature 30
 log and graph scale 30

M

main menu 26
 marking a waypoint 40
 menu, main 26
 menu key 22
 messages 43
 mounting bracket 7
 mounting the bracket assembly 6
 mounting the fishfinder 6
 mounting the transducer 9
 mounting the transducer on a transom 12
 mounting the transducer on a trolling motor 10

N

narrow beam 3, 35
 narrow data fields 37
 NMEA 16, 29, 32, 33, 41
 NMEA address 16

NMEA data 38
 NMEA device 16
 NMEA input/output 16, 40
 NMEA setup 32
 numbers page 26

O

optional accessories 42

P

packing list 1
 pages, understanding the 23
 page key 22
 pause key 22
 pausing a sonar or flasher page 39
 pointer 16, 38
 pointer mode 40
 pop-up message 43
 position format 33
 power/backlight key 20, 21, 22
 power/data and transducer cables 5, 7
 power up 20, 21

Q

quit key 22

R

range 35
 range keys 22
 reset odometer 32
 ROCKER key 22

S

scale 27
 scale, log and graph 30
 screen, cleaning the iii
 scroll 36
 scroll speed 28
 selecting a location 5
 selecting a location for shoot-thru-hull installation 13
 selecting a transom mount location 11
 setting an alarm 31
 shallow water alarm 31
 shoot-thru-hull installation 13
 software language 21
 software version 32
 soft bottom 25
 soft structure 4
 sog (speed over ground) 38
 sonar 2
 sonar page 23
 sonar sub tab 31
 sonar tab 28
 sound waves 2
 span 36
 specifications 42
 speed units 33
 split sonar page 24
 adjustment menu for 24
 split zoom 24
 storage iii

strongest sonar returns 4
 stw (speed through water) 38
 surface clutter 4
 surface mounting the fishfinder 6
 swap split 37
 swivel base 6
 swivel mount bracket 7
 symbols, fish 27
 system sub tab 31
 system tab 32

T

target level 35
 temperature 27
 temperature graph 37
 temperature log 30
 temperature range for the fishfinder 5
 temperature tab 30
 temperature units 33
 testing the installation 20
 testing the transom mount installation 21
 time 34
 timer 31, 39
 time (time of day) 39
 time duration 30
 time format 34
 time tab 33
 time zone 34
 tools 37

transducer 2, 13
transducer, assembling the 9
transducer cables 5
transducer type 28
transom 12
transom, mounting on a 11
transom mount installation 20
trolling motor, mounting on a 10
turn 39
turn on or off the fishfinder 21

U

underwater waypoints 41
units tab 33
using the keypad 22

V

view 36
vmg (velocity made good) 39
volt 39
voltage 15, 20, 21

W

warranty 44
water immersion iii
water speed 27, 29, 37
water temperature 37
water temperature alarm 31
waypoint 41
waypoint, marking a 40
weakest returns 4

whiteline 35
wide beam 3, 35
wide data fields 37
wiring harness 15, 16
wiring to an NMEA device 16
wiring to a GPS 16
wtr temp (water temperature) 39

X

xte (crosstrack error) 39

Z

zoom 36
zoom, split 24

Visit the Garmin Web site at www.garmin.com.



© 2005, 2007 Garmin Ltd. or its subsidiaries

Garmin International, Inc.
1200 East 151st Street, Olathe, Kansas 66062, USA

Garmin (Europe) Ltd.
Liberty House, Hounsdown Business Park, Southampton, Hampshire, SO40 9RB UK

Garmin Corporation
No. 68, Jangshu 2nd Road, Shijr, Taipei County, Taiwan

Part Number 190-00658-00 Rev. D